

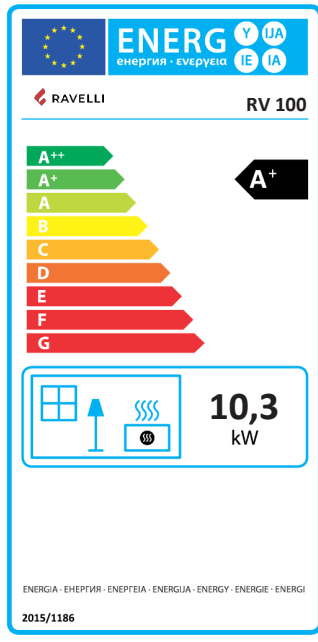



RV 100

	SCHEDA PRODOTTO	PRODUCT DATASHEET
	FICHE DE PRODUIT	PRODUCTKAART
	PRODUKTDATENBLATT	FICHA DEL PRODUCTO

EU 2015/1186

	Marca / Trademark / Marque / Merk / Marke / Marca	Ravelli
	Modello / Model / Modèle / Model / Modell / Modelo	RV 100
	Classe di efficienza energetica / Energy Efficiency class / Classe d'Efficacité Énergétique / Energie-efficiëntieklasse / Energieeffizienzklasse / Clase de eficiencia energética	A+
	Potenza termica diretta / Direct thermal power / Puissance thermique directe / Directe warmteafgifte / Direkte Wärmeleistung / Potencia calorífica directa	10,3 kW
	Potenza termica indiretta / Indirect thermal power / Puissance thermique indirecte / Indirecte warmteafgifte / Indirekte Wärmeleistung / Potencia calorífica indirecta	--
	Indice di efficienza energetica / Energy Efficiency Index / Indice de eficiencia energética / Energie-efficiëntie-index / Energieeffizienzindex / Índice de eficiencia energética	125
	Efficienza utile (Potenza nominale) / Useful efficiency (Nominal power) / Rendement utile (puissance nominale) / Nuttig rendement (bij nominale) / Brennstoff-Energieeffizienz (Nennwärmeleistung) / Eficiencia energética útil (potencia nominal)	89,0 %
	Efficienza utile (Potenza ridotta) / Useful efficiency (Reduced power) / Rendement utile (puissance minimale) / Nuttig rendement (bij minimale) / Brennstoff-Energieeffizienz (Mindestlast) / Eficiencia energética útil (potencia mínima)	91 %
	Rispettare le avvertenze e le indicazioni di installazione e manutenzione periodica riportate nel manuale di istruzioni. / Comply with the warnings and instructions concerning installation and routine maintenance provided in the instruction manual. / Respecter les avertissements et les indications sur l'installation et l'entretien périodique fournis dans le manuel d'instructions. / Neem de waarschuwingen en instructies voor installatie en periodiek onderhoud in acht zoals aangegeven in de hoofdstukken van de gebruiksaanwijzing. / Beachten Sie die Warnungen und Hinweise betreffend die Installation und regelmäßige Wartung in der Bedienungsanleitung. / Respete las advertencias y las indicaciones de instalación y mantenimiento periódico, detalladas en los capítulos del manual de instrucciones.	

	PRODUCT DATASHEET	FICHA DO PRODUTO
	ΔΕΛΤΙΟ ΠΡΟΪΟΝΤΟΣ	PRODUKTBLAD
	KARTA PRODUKTU	PODATKOVNI LIST IZDELKA

EU 2015/1186

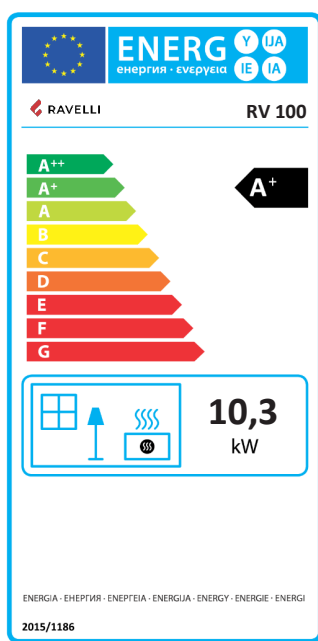
	Trademark / Marca / Μάρκα / Mærke / Marka / Blagovna znamka	Ravelli
	Model / Modelo / Μοντέλο / Model / Model / Model	RV 100
	Energy Efficiency class / Classe de Eficiência Energética / Κατηγορία ενεργειακής απόδοσης / Energiklasse / Klasa efektywności energetycznej / Razred energetske učinkovitosti	A+
	Direct thermal power / Potência calorífica direta / Άμεση θερμική ισχύς / Direkte varmedelse / Bezpośrednia moc produktu / Neposredna izhodna toplotna moč	10,3 kW
	Indirect thermal power / Potência calorífica indireta / Έμμεση θερμική ισχύς / Indirekte varmedelse / Pośrednia moc produktu / Posredna izhodna toplotna moč	--
	Energy Efficiency Index / Índice de eficiência energética / Δείκτης ενεργειακής απόδοσης / Indeks energieffektivitet / Wskaźnik efektywności energetycznej / Kazalo energetske učinkovitosti	125
	Useful efficiency (Nominal power) / Eficiência energética útil (potência nominal) / Ωφέλιμη ενεργειακή απόδοση (ονομαστική ισχύς) / Virkningsgrad (nominel varmedelse) / Sprawność użytkowa (nominalnej mocy) / izkoristek energije (nazivni izhodni moči)	89,0 %
	Useful efficiency (Reduced power) / Eficiência energética útil (potência mínima) / Ωφέλιμη ενεργειακή απόδοση (ελάχιστο ισχύς) / Virkningsgrad (mindste varmedelse) / Sprawność użytkowa (minimalnym mocy) / izkoristek energije (nazivni izhodni moči)	91 %
	Comply with the warnings and instructions concerning installation and routine maintenance provided in the instruction manual. / Respeitar as advertências e as indicações de instalação e manutenção periódica referidas nos capítulos do manual de instruções. / Τηρείτε τις προειδοποιήσεις και τις οδηγίες εγκατάστασης και περιοδικής συντήρησης που αναφέρονται στα κεφάλαια του εγχειριδίου των οδηγιών. / Overhold advarslerne og angivelserne for installation og vedligeholdelse, som angivet i kapitel i brugsvejledningen. / Należy przestrzegać ostrzeżeń i wskazań dotyczących instalacji i okresowej konserwacji podanych w rozdziałach w instrukcji obsługi. / Upoštečajte opozorila in navodila za namestitve in redno vzdrževanje, navedena v poglavjih priročnika z navodili.	

DECLARATION OF PERFORMANCE

Declaration of performance according to Regulation (EU) 305/2011
n. : 259CPR13.07



1. Unique identification code of the product type:
20056FR03, residential space heating appliance fired by wood pellets
EN 14785:2006
2. Type, batch or serial number or any other element allowing identification of the construction product as required under Art. 11(4):
RV 100,
3. Intended use or uses of the construction product, in accordance with the applicable harmonised technical specification, as foreseen by the manufacturer:
Residential space heating appliance fired by wood pellets
4. Name, registered trade name or registered trademark and contact address of the manufacturer as required by Art. 11 (5):
Ravelli
Aico S.p.A.
Via A. Kupfer, 31
25036 Palazzolo s/O (Bs) Italia
5. Where applicable, name and contact address of the authorised representative whose mandate covers the tasks specified in Article 12(2):

6. System or systems of assessment and verification of constancy of performance of the construction product as set out in Annex V:
System 3, System 4
7. In case of the declaration of performance concerning a construction product covered by a harmonised standard:
The notified laboratory IMQ (NB 0051) performed the determination of the product type on the basis of type testing under system 3 and issued test report CS20-0052218-01
8. Declared performances:

Harmonized technical specification:	EN 14785:2006
Essential characteristics	Performance
Fire safety	
Reaction to fire	A1
Distance to combustible materials	Minimum distances (mm): rear = 200 sides = 300 front = 1000 ceiling = -- floor = 0
Risk of burning fuel falling out	Pass
Emission of combustion products (at 13% of O ₂)	Nominal heat output CO 0,010 % - 130 mg/Nm ³ NOx 127 mg/Nm ³ OGC 1 mg/Nm ³ PM 18 mg/Nm ³ Reduced heat output CO 0,017 % - 217 mg/Nm ³ OGC 4 mg/Nm ³
Surface temperature	Pass
Electrical safety	Pass
Cleanability	Pass
Maximum operating pressure	--
Flue gas temperature at nominal heat output	173 °C
Mechanical resistance(to carry a chimney/flue)	NPD
Nominal heat output	10,3 kW
Room heating output	10,3 kW
Water heating output	--
Efficiency	η 89,0 % Nominal heat output η 91 % Reduced heat output

9. The performance of the product identified in points 1 and 2 is in conformity with the declared performance in point 8. This declaration of performance is issued under the sole responsibility of the manufacturer identified in point 4.

Signed for and on behalf of the manufacturer **Claudio Mezzalana, Operations Manager**

Place **Palazzolo sull'Oglio**

Date **02/02/2021**

Sign

Dichiarazione di conformità UE
EU Declaration of Conformity
Declaration de Conformite UE
(DoC)



Il costruttore
The manufacturer
Le fabricant

Aico S.p.A.
Via A. Kupfer, 31
25036 Palazzolo s/O (Bs) – Italy
ph: +39 030 74 02 939, e-mail:info@ravelligroup.it

DICHIARA che la dichiarazione viene rilasciata sotto la propria responsabilità e si riferisce al seguente prodotto:

DECLARES that the DoC is issued under our sole responsibility and belongs to the following product:

DÉCLARE que la déclaration est délivré sous notre seule responsanilité et elle se refère au suivant produit:

Tipo di prodotto
Product type
Type de produit

Stufa a pellet
Pellet stove
Poêle à granulés de bois

Marchio
Trademark
Marque

Ravelli

Modello
Model
Modèle

RV100

L'oggetto della dichiarazione di cui sopra è conforme alla pertinente normativa di armonizzazione dell'Unione:

The object of the declaration described above is in conformity with the relevant Union harmonisation legislation:

L'objet de la déclaration décrit ci-dessus est conforme à l'harmonisation de l'Union concernant la législation la directive:

- **2014/30/EU, EMCD**
- **2014/35/EU, LVD**
- **2011/65/EU, RoHS**

Sono state applicate le seguenti norme armonizzate e/o specifiche tecniche:

The following harmonised standards and/or technical specifications have been applied:

Les normes et les spécifications techniques harmonisées suivantes ont été appliquées:

EN 55014-1 EN 60335-1
EN 55014-2 EN 60335-2-102
EN 61000-3-2 EN 62233 EN 50581
EN 61000-3-3

Palazzolo Sull'Oglio (BS), ITALY
15/03/2018

(Giovanni Scarlini, CEO)

Preface

Dear Customer, We would like to thank you for choosing one of our stoves.

We invite you to read this manual carefully, before starting installation and use, so that you are able to benefit from all of its characteristics better and in full safety. It contains all necessary information for correct installation, start-up, operation, cleaning, maintenance, etc.

Keep this manual in a suitable location, do not discard it without reading it.

Incorrect installation, maintenance and improper use of the product relieve the Manufacturer of all liability deriving from use of the stove.

For further information and requirements contact your Ravelli-authorized Technical Assistance Centre.

All rights reserved. No part of this instructions manual can be reproduced or transmitted through any electronic or mechanical means, including photocopies, recordings or any other storage system, for other purposes that are not exclusively use by the buyer's staff, without the express written consent of the Manufacturer.

Sommario	
Preface.....	7
IDENTIFICATION	10
Stove identification	10
Manufacturer identification	10
Reference standards	10
Label	10
WARRANTY	11
Certificate of warranty.....	11
Warranty conditions.....	11
Registration of warranty	11
Info and problems	11
GENERAL INFORMATION	12
Supply and safe-keeping	12
Language	12
Symbols used in the manual	12
SAFETY MEASURES	12
General safety warnings	12
Residual risks	13
DESCRIPTION OF THE STOVE.....	14
Intended use	14
Reasonably foreseeable incorrect use	14
Obligations and forbidden actions	15
Characteristics of the fuel	16
Non-permitted fuels.....	16
TECHNICAL CHARACTERISTICS	17
Technical diagram RV 100.....	18
Main parts	19
Description of operation.....	19
Recharge the fuel	20
User training	20
Safety devices.....	21
The Majolica cladding and coatings.....	22
SHIPPING AND INSTALLATION	24
Safety warnings for transportation and installation	24
Set-ups for the smoke evacuation system	25
Installation	26
CONNECTIONS	29
Connection with external air intake.....	29
Chimney connection	29
Connection of external thermostat	30
Testing and commissioning	30
Electric scheme RV 100	30
DESCRIPTION OF THE FUNCTIONING AND SYMBOLOGY OF THE DISPLAY.....	31
PPROCEDURES FOR USE	31
Checks prior to start-up	31
Pellet auger loading	31
Set of the room temperature	32
Set of the working power.....	33

OPERATING PHASES OF THE APPLIANCE	33
<i>Sequence of ignition phases</i>	33
<i>Modulation</i>	33
<i>Description of menu functions</i>	33
<i>Remote control</i>	39
<i>Stove phase general layout</i>	40
<i>Description of alarms</i>	40
MAINTENANCE	42
<i>Safety warnings for maintenance</i>	42
<i>Cleaning</i>	42
STORAGE AND DISPOSAL	47
<i>Disposal</i>	47
TROUBLESHOOTING	47
<i>The stove does not work</i>	47
<i>Difficult lighting</i>	47
<i>Smoke leakage</i>	47
<i>The glass gets dirty easily</i>	47
<i>Downtime (end of season)</i>	47

IDENTIFICATION

Stove identification

Type of product	PELLET STOVE
Trademark	Ravelli
Model	RV 100

Manufacturer identification

Manufacturer	Aico S.p.A. Via Consorzio Agrario, 3/D - 25032 Chiari (BS) - Italy T. + 39 030 7402939 info@ravelligroup.it www.ravelligroup.it
--------------	--

Reference standards

The RV 100 stoves that this manual refers to are compliant with the regulation:

305/2011, CONSTRUCTION PRODUCT REGULATION

and the following directives

2014/30/EU, EMC

2014/35/EU, LVD

2011/65/EU 2015/863/EU, 2017/2102/EU, (RoHS)

2009/125/EC (Ecodesign)

And the following harmonised standards and/or technical specifications have been applied:

EN 14785; EN 55014-1; EN 55014-2; EN 61000-3-2; EN 61000-3-3; EN 60335-1; EN 60335-2-102; EN 62233; EN 50581; ETSI EN 300220-1

All local regulations, including those referring to national and European standards, must be respected when installing the appliance.

Label

The following symbols are used on the label:

$P_{IN,nom}$	Heat input power (max)	$P_{IN,part}$	Heat input power (min)
P_{nom}	Nominal power	P_{part}	Reduced power
CO_{nom}	CO at nominal power	CO_{part}	CO at reduced power
η_{nom}	Efficiency at nominal power	η_{part}	Efficiency at reduced power
p_{nom}	Minimum draught at nominal power	T_{nom}	Flue gas temperature at nominal power
230 V - 50 Hz	Alimentation		
Distance to combustible materials			
d_{S-L}	Left side	d_C	Ceiling
d_{S-R}	Right side	d_F	Front
d_R	Rear	d_B	Floor

n.d.: undeclared data

Model: RV 100

APPARECCHIO PER IL RISCALDAMENTO DOMESTICO ALIMENTATO A PELLETTI DI LEGNO RESIDENTIAL SPACE HEATING APPLIANCE FIRED BY WOOD PELLETS APPAREIL DE CHAUFFAGE DOMESTIQUE À CONVECTION À GRANULES DE BOIS APARATO DE CALEFACCION DOMESTICA ALIMENTADO CON PELLETS DE MADERA HUISHOUDELIJKE RUIMTEVERWARMINGSTOESTELLEN GESTOOKT MET GEPERST HOUT RAUMHEIZER ZUR VERFEUERUNG VON HOLZPELLETS			
$P_{IN,nom}$	11,5 kW	$P_{IN,part}$	4,7 kW
P_{nom}	10,3 kW	P_{part}	4,3 kW
$CO_{nom}(13\%O_2)$	0,0104 %	$CO_{part}(13\%O_2)$	0,0174 %
η_{nom}	89,0 %	η_{part}	91,0 %
p_{nom}	12 Pa	0,12 mbar	
T_{nom}	173 °C	W	300 W
230 V 50 Hz			
Usare solo il combustibile raccomandato: Use only recommended fuel: Utilizer seulement les combustibles recommandés: Use solo el combustible recomendado: Gebruik alleen de aanbevolen brandstof: Nur empfohlene Brennmaterial verwenden:		Pellet di legno Wood pellet Granule de bois Pellet de madera Houtpellet Holzpellets Ø 6 mm	

Leggere le istruzioni d'uso / Read and follow the operating manual / Lire et suivre le mode d'emploi / Lea y respete le manual de operacion / Lees en volg de handleiding voor bediening / Bitte lesen und befolgen Sie die Montage und Nutzungsanweisungen

Distanza minima da materiali infiammabili	d_{S-R}	300 mm
Minimum distance from flammable materials	d_{S-L}	300 mm
Distance moindre de matériels inflammables	d_R	200 mm
Distancia mínima de materiales inflamables	d_C	N.d. mm
Minimale afstand van brandbare materialen	d_F	1000 mm
Mindestabstand zu brennbaren Materialien	d_B	0 mm

D.o.P. n° 259CPR13.07 (Notified Body 0051)

EN 14785:2006

Anno di produzione: 2021



WARRANTY

Certificate of warranty

Ravelli thanks you for the trust granted with the purchase of one of its products and invites the purchaser to:

- read the installation, use and maintenance instructions for the product;
- read the warranty conditions contained below.

Warranty conditions

The warranty for the Customer is acknowledged by the Dealer under the terms of law.

The Dealer acknowledges the warranty only if the product has not been tampered with and only if it has been installed in accordance with the Manufacturer's instructions.

The limited warranty covers manufacturing material defects, as long as the product has not broken due to an incorrect use, negligence, incorrect connection, tampering, installation errors.

The warranty becomes null and void even if only one requirement in this manual is not complied with.

The following are not covered by warranty:

- the combustion chamber refractory stones;
- the door glass;
- the gaskets;
- the paint job;
- the stainless steel or cast iron combustion grille;
- the resistance;
- the Majolica cladding;
- the aesthetic parts;
- any damages caused by unsuitable installation and/or use of the product and/or shortcomings on the part of the customer.

The use of poor quality pellet or any other unauthorised fuel may damage the product's components, cause its warranty to be voided and as a result eliminate the connected manufacturer liability.

It is therefore recommended to use good quality pellet that fulfils the requirements listed in the dedicated chapter.

All damages caused by transportation are not recognised, for this reason it is recommended to carefully check goods upon receipt, immediately warning the reseller of any damage.

Registration of warranty



To activate the warranty, it is necessary to register the product on the Guarantee Portal on the website www.ravelligroup.it, by entering your data and the purchase receipt.

Info and problems

Dealers authorised by Ravelli use a trained Technical Service Centre network to meet the Customer's requirements. For any information or request for assistance, please contact your Dealer or the Technical Service Centre.

GENERAL INFORMATION

Supply and safe-keeping

The manual is supplied in printed format.

Keep this manual safe, with the stove, so that the user can consult it easily.

The manual is an integral part, for safety reasons, therefore:

- **it must be kept intact** (in full). If it gets lost or ruined it is necessary to immediately ask for a new copy:
- **it must be kept with the stove until demolition** (including relocation, sale, rental, lease, etc....).

The Manufacturer will not be held liable for improper use of the stove and/or damage caused by operations that are not set forth in the technical documentation.



Language

The original manual was written in Italian.

Any translations into additional languages must be carried out based on the original instructions.

The Manufacturer is liable for the information contained in the original instructions; the translations into different languages cannot be fully verified therefore if any inconsistency arises it will be necessary to follow the text in the original language or contact our Technical Documentation Office.

Symbols used in the manual

symbol	definition
	This symbol is used to identify particularly important information in the manual. This information also concerns the safety of users involved in using the stove.
	This symbol is used to identify important warnings for the safety of the user and/or the stove.

SAFETY MEASURES

General safety warnings









 Read this instructions manual carefully before stove installation and use. Failure to observe the instructions set forth herein can void the warranty and/or cause damage to property and/or people.

 Stove installation, system verification, operation verification and initial calibration must be carried out exclusively by qualified and authorised staff.

 The stove needs to be connected to a single chimney that guarantees the draught declared by the Manufacturer and observes the installation regulations that apply to the installation site.

 The room where the stove is installed must have an air intake.

 The stove must not be used as an incinerator or differently from its purpose

-  Do not use any fuel other than fire pellet. It is strictly forbidden to use liquid fuels.
-  It is prohibited to use the stove with the door or ash drawer open or the glass broken.
-  Do not touch the hot surfaces of the stove without suitable protective equipment, to avoid getting burned. When it is running, the outer surfaces reach hot temperatures to the touch.
-  It is forbidden to make unauthorised changes to the stove.
-  Before using the stove it is necessary to know the position and function of the controls.
-  If the chimney catches fire you must call the fire brigade.
-  Only use original spare parts. Any tampering and/or replacements that have not been authorised by Ravelli can pose a danger to the user's safety.
-  In the event of particularly adverse weather conditions, the safety systems could intervene and switch off the stove. In any case, do not disable the safety systems.

Residual risks

The stove was designed so as to guarantee the user's essential safety requirements.

Safety was integrated into the stove's design and construction as much as possible.

For every residual risk there is a description of the risk and the zone or part that it applies to (unless the risk applies to the entire stove overall). Procedure-related information is also provided on how to avoid the risk and on the correct use of the personal protective equipment required by and made compulsory by the Manufacturer.

residual risk	description procedure-related information
Risk of burns 	When the stove is running, it may reach high temperatures to the touch, especially on its external surfaces. Take care to avoid burns and use the specific tools if necessary. Use the supplied glove to open pellet cover for loading operations.

DESCRIPTION OF THE STOVE

Intended use

The appliance in question is intended for:

operation	allowed fuel	forbidden	setting
Domestic space heating by burning:	pellet	Any fuel other than the permitted ones.	Residential or Commercial

The stove is designed and built to work safely if:

- it is installed by qualified staff according to the specific standards;
- it is used within the limits declared in the contract and herein;
- the operating manual procedures are followed;
- routine maintenance is carried out according to the times and methods set forth;
- extraordinary maintenance is promptly carried out when needed;
- safety devices are not removed and/or bypassed.

 This stove must be intended for the use it was specifically designed for.

Reasonably foreseeable incorrect use

Reasonably foreseeable incorrect use is listed below:

- using the stove as an incinerator;
- using the stove with fuel other than pellet;
- using the stove with liquid fuels;
- using the stove with the door open and the ash drawer out.

Any use of the appliance other than intended must be preventively authorised in writing by the Manufacturer. Without said written authorisation, the use is considered “improper”. Any contractual and non-contractual liability of the manufacturer is excluded for damages to persons, animals or property due to installation and maintenance adjustment errors and improper use.

Obligations and forbidden actions

Obligations

The user must:

- read this instructions manual before performing any operation on the stove;
- the appliance must not be used by children under the age of 8 or by people with reduced physical, sensorial or mental capacities or without experience or without the necessary knowledge, and always with supervision;
- do not use the stove improperly, i.e. for uses other than those described in the “INTENDED USE” paragraph;
- it is strictly forbidden to use liquid fuels;
- keep objects that are not heat and/or flame-resistant at a safe distance;
- only and exclusively load the stove with pellet with the characteristics described herein;
- connect the stove to a regulation chimney;
- provide a suitable system for the supply of combustion air (air intake or intake duct for watertight stoves);
- always perform maintenance with the stove off and cold;
- perform cleaning activities at the frequency stated herein;
- use original parts recommended by the Manufacturer.

Forbidden actions

The user must never:

- remove or change the safety devices without authorisation;
 - perform operations or manoeuvres of his/her own initiative that are not part of his/her job description, meaning that he/she might jeopardise his/her own safety and that of others;
 - use fuels other than pellet and those allowed for lighting;
 - use the stove as an incinerator;
 - use flammable or explosive substances near the stove during operation;
 - use the stove with the door open and/or with the glass ruined or broken;
 - close the combustion air and smoke outlet openings, whatsoever;
 - use the stove to dry laundry;
 - replace or change some of the stove parts.
-
-

Characteristics of the fuel

Wood pellet is a fuel made of pressed wood sawdust, often recovered from processing scraps of carpentries. The material used cannot contain any extraneous substance such as, for example, glue, lacquer or synthetic substances.

The sawdust, once it has been dried and cleaned from impurities, is pressed using a die with holes: as a result of high pressure, the sawdust heats up by activating the natural wood binders; this way the pellet maintains its shape even without adding artificial substances.

Wood pellet density varies based on the type of wood and can exceed that of natural wood by 1.5 - 2 times.

The cylinders have a diameter of 6 mm and a variable length between 10 and 40 mm.

Their density is equal to approximately 650 kg/m³. Due to their low water content (< 10%) they have a high energy content.

The UNI EN ISO 17225-2:2014 standard (that replaces the EN PLUS standard) defines pellet quality by specifying three classes: A1, A2 and B. Maintain fuels and other flammables at a suitable distance.

Ravelli recommends using wood pellet classified A1 and A2 according to the EN ISO 17225-2:2014 standard, or certified DIN PLUS (more restrictive than the A1 class) or ONORM M 7135. Pellet may be light or dark coloured, it is normally bagged into bags that show the name of the producer, the main characteristics and classification according to standards.



Pellets must be transported and stored in a dry area. Upon contact with humidity they swell and become unusable



It is therefore necessary to protect them from humidity, both during transport and during storage.

Non-permitted fuels

We recommend not using the following materials as fuel:

- wood
- treated wood (painted, lacquered, glued wood etc.);
- sawdust or chips
- liquid fuel
- coal or other fossil fuels
- plastic and derivatives
- treated paper and cardboard
- waste
- fuels that release toxic or polluting substances

Using these fuels, on top of being forbidden due to the emission of polluting and harmful substances, causes the stove to deteriorate more rapidly and debris to accumulate in the stove and in the smoke evacuation system, thereby reducing performance and safety.



The gases produced by these fuels are dangerous for the environment and for your health!



Using fuel that is not compliant with the above will void the warranty.

TECHNICAL CHARACTERISTICS

	U	RV 100
Energy efficiency class	--	A+
Heating input reduced - nominal	kW	4,7 - 11,5
Heating output reduced - nominal	kW	4,3 - 10,3
Red. - Nom. Yield	%	91 - 89,0
Hourly consumption	kg/h	0,96 - 2,36
Loading interval	h	26 - 11
Max. heating volume*	m ³	245 - 290
CO at 13% of O ₂	%	0,017 - 0,010
	mg/m ³	217 - 130
OGC at 13% of O ₂	mg/m ³	4 - 1
NO _x at 13% of O ₂	mg/m ³	120 - 127
PM at 13% of O ₂	mg/m ³	20 - 18
Smoke temperature	°C	99 - 173
Smoke flow	g/s	6 - 8
Minimum draft	Pa - mbar	11 - 0,11
Electrical connection	Hz - V	230 - 50
Electrical power consumption max.	W	300
Electrical power consumption reduced - nominal	W	58 - 94
Stand-by electrical consumption	W	1,3
smoke air inlet Ø	mm	50
smoke outlet pipe Ø	mm	80
Hopper capacity	kg	25
Seasonal energy efficiency	%	85,4
Type of room temperature control	with electronic room temperature control plus week timer	
Other control options	with distance control option	

The data shown here is provided as a guideline and is not binding, and may change based on what type and quality of wood is used. Ravelli reserves the right to make any changes in order to improve product performance.

* Heatable volume based on the requested power equal to 35 W/m³ and 55 W/m³

Minimum clearances from combustible materials	
	RV 100
R Right side	300 mm
L Left side	300 mm
A Rear	200 mm
B Front	> 800 mm

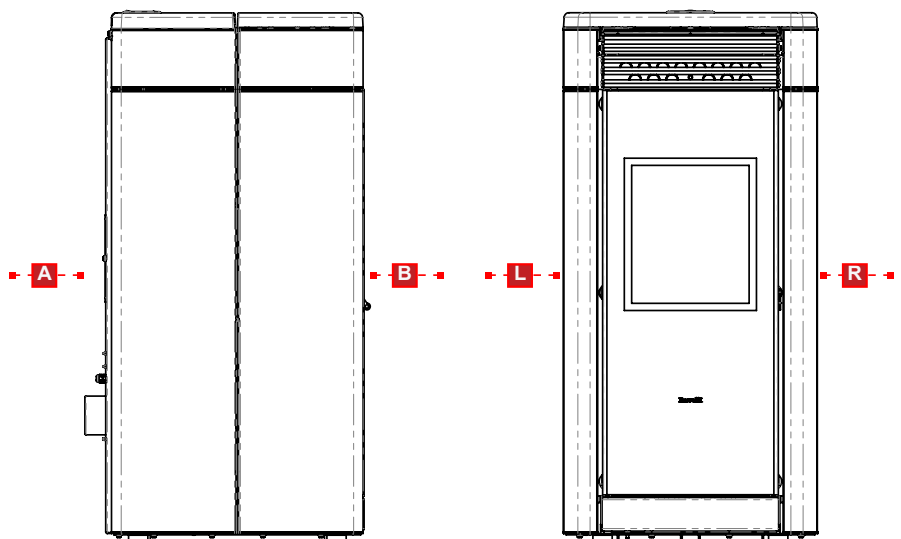

Measurements

	Unit of measurement	RV 100
Height	mm	1105
Width	mm	524
Depth	mm	554
Weight	kg	120

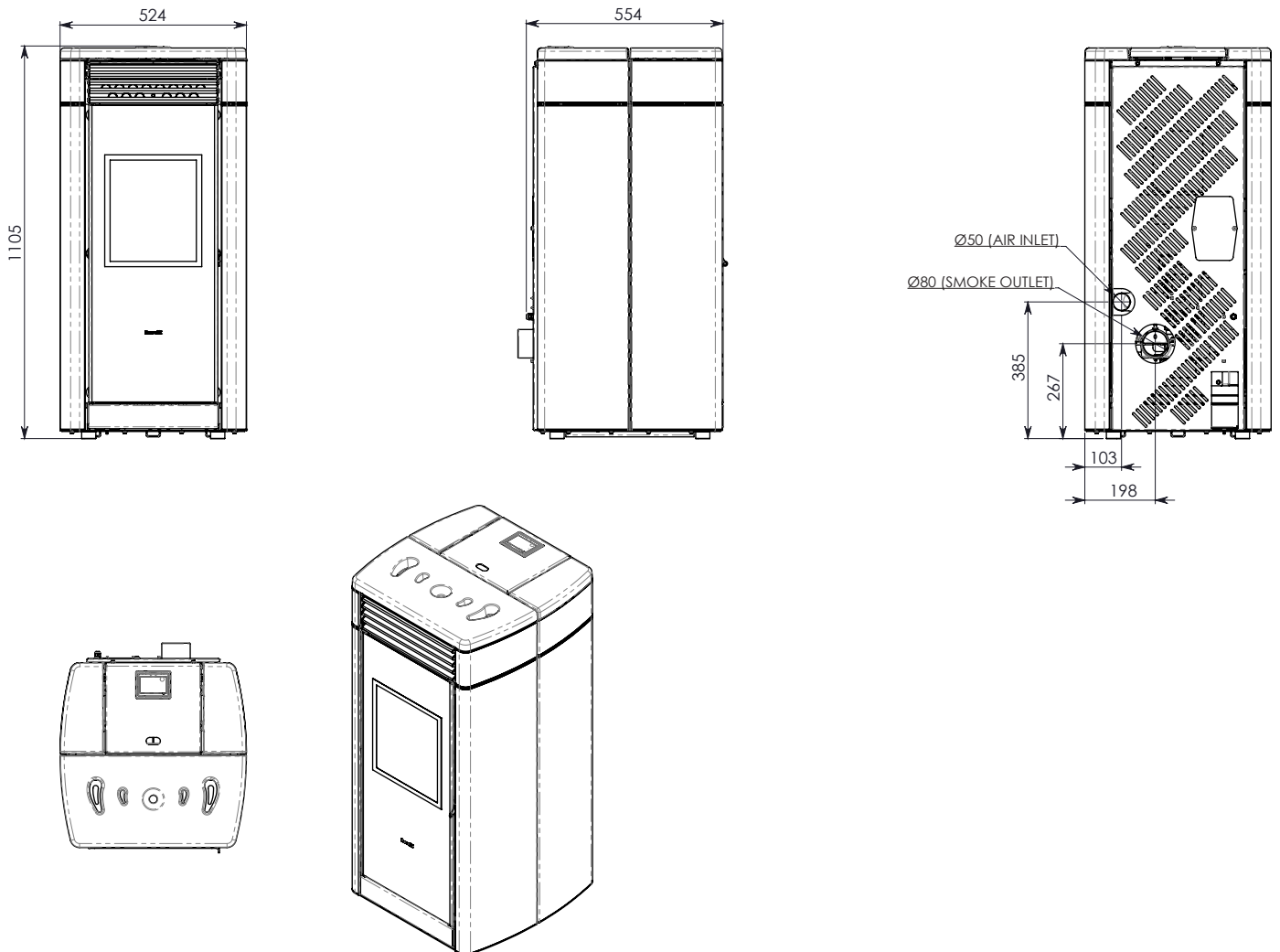
Technical diagram RV 100

Main parts

	element		element
A	Grid for air passage	F	Combustion chamber
B	Combustion chamber door	G	Grid for ashes
C	Ashes drawer	H	Brazier
D	Pellet cover	I	Reset thermostat
E	Control panel		

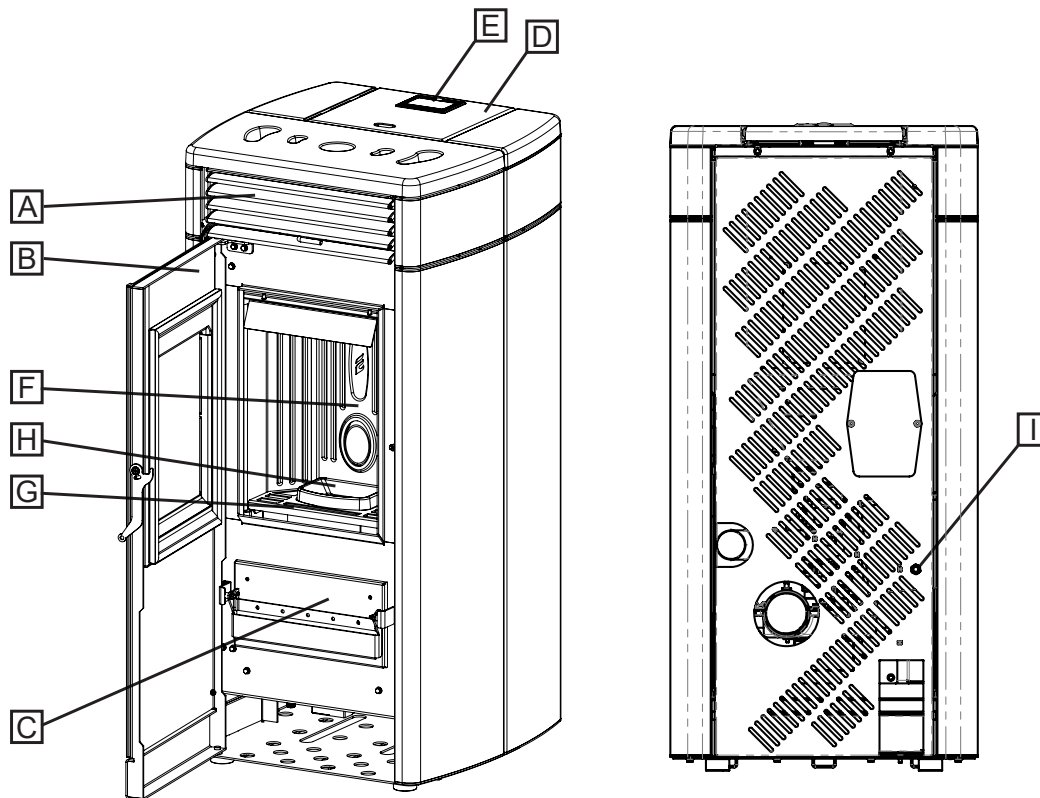

Description of operation

Ravelli pellet stoves RV 100 are appliances for domestic heating powered by wood pellets with automatic loading. They are suitable for use as a secondary heating system or as a support for the main heating system.

The heat generated by pellet combustion is diffused in the installation room thanks to the ventilation, as well as by radiation and natural convection.

The stove is controlled by an electronic control unit that manages the start-up, operation and shutdown phases and also includes many other functions for control, programming and safety.

The user can choose the operating power from 5 levels, or set the temperature to be maintained in the room. In this case the stove will manage the power to ensure maximum comfort. Among the functions of the electronic control unit there is also that of being able to program the start-up and shutdown of the stove, setting the weekly chronothermostat.

FUNCTION	DESCRIPTION
Ventilation	Automatic
Fire pot	Removable
Chronothermostat	Weekly 4 programs
RDS system	Available
Thermal reset	Manual

Recharge the fuel

 Use only wood pellets, the characteristics shown in this manual.

 During pellet loading prevent the pellet bag from coming into contact with hot surfaces.

 It is not recommended to empty the pellet bag directly into the hopper to avoid depositing wood sawdust on the bottom of the hopper.

To load the pellets inside the hopper, proceed as described below:

	step
1	Open the pellet hopper cover
2	Pour the pellets into the hopper
3	Close the pellet hopper cover

User training

Once installation is complete, the user must always be fully trained in the functions and characteristics of the stove by the technician authorized by Ravelli to ensure optimal and safe use.

The training should cover the following topics:

- Description of the stove, its operation and basic settings
- How to turn the stove on and off safely
- Fuel storage and refilling
- What to do in the event of an alarm, in particular that of "no ignition"
- How to clean the stove correctly and the importance of performing it on a regular basis
- It is advisable to schedule the first annual maintenance

Safety devices

The stove has been designed and equipped with safety systems to minimize user risks.

It is equipped with the safety devices listed in the following table, which also intervene in case of failure of the electronic board.

Element	Description
Pellet tank thermostat	If the temperature exceeds the set safety value, it immediately stops the pellet loading motor and the stove is automatically switched off; to restart it, it is necessary to wait until it has cooled down and manually reset the thermostat, using the appropriate button.
Pressure switch	If the pressure in the smoke outlet duct is too high (a sign that the smoke evacuation system is obstructed) it immediately stops the pellet loading motor and the stove switches off automatically.
Electrical safety	In case of failure of the electrical components or wiring, the fuse and grounding keep the appliance safe. It is necessary that the electrical system of the house is up to standard, equipped with a grounding circuit and all the safety systems required by the standards.

It should be noted that the stove's operating program has been designed to stop stove operation in the event of malfunctions:

Anomalies	Description
Flue gas temperature	If the temperature probe at the smoke outlet detects temperatures that are too high, the stove is switched off and the relative alarm is displayed.
Smoke fan break	If the fan stops, the electronic board blocks the supply of pellets and the alarm is displayed.
Gear motor failure	If the gear motor stops, the appliance switches off safely.
Temporary power failure	If a power failure occurs during operation, when the power returns the stove goes into cooling mode.
No ignition	If no flame develops during the ignition phase, the stove goes into alarm.



It is forbidden to tamper with the safety devices. Restarting the product is only possible after eliminating the cause that caused the intervention of the safety system. To understand which anomaly occurs, consult this manual which explains, depending on the alarm message that the device displays, how to intervene on it.



If the problem persists, contact the Support Service.

The Majolica cladding and coatings

The Majolica cladding is artisan-crafted and hand-finished.

For this reason there may be minor imperfections on the surface such as slight discoloration and hair cracks, which are considered characteristics that make each Majolica a unique piece.

To mount the Majolica cladding and the coatings, follow the steps below.



Since the Majolica cladding is made with a delicate material, we recommend handling it with care during cleaning and avoiding sudden impact that may cause damage.

1

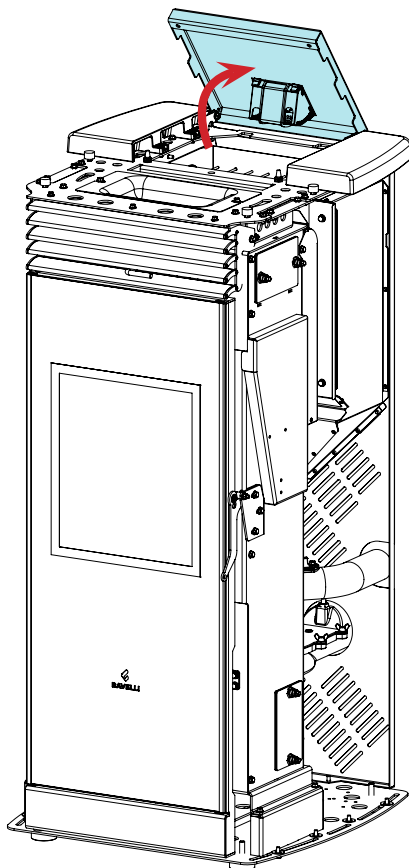

2



3

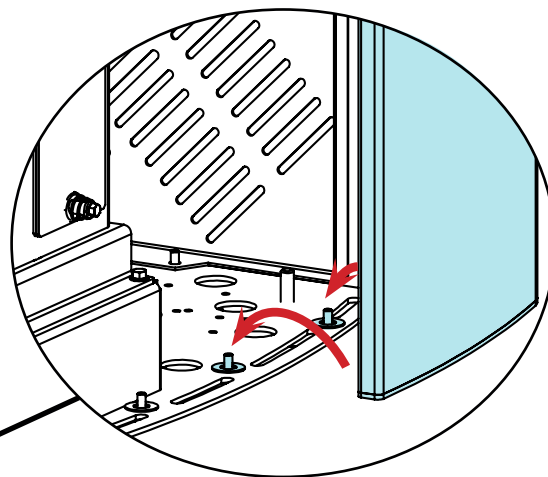
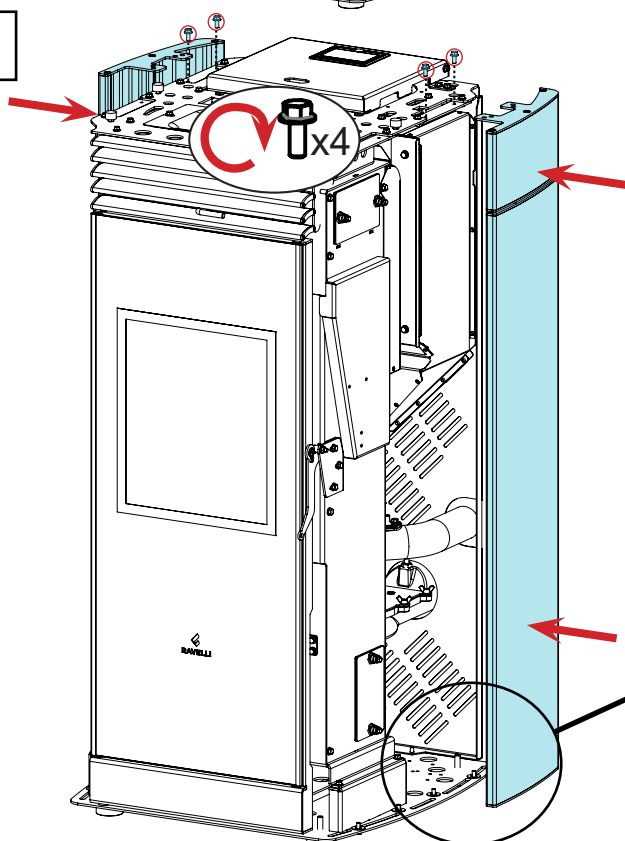

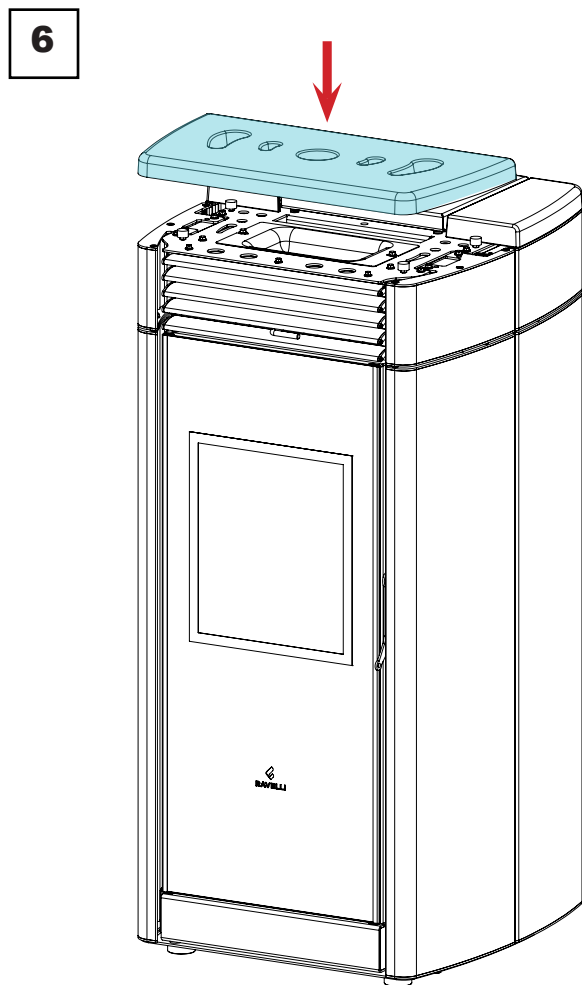
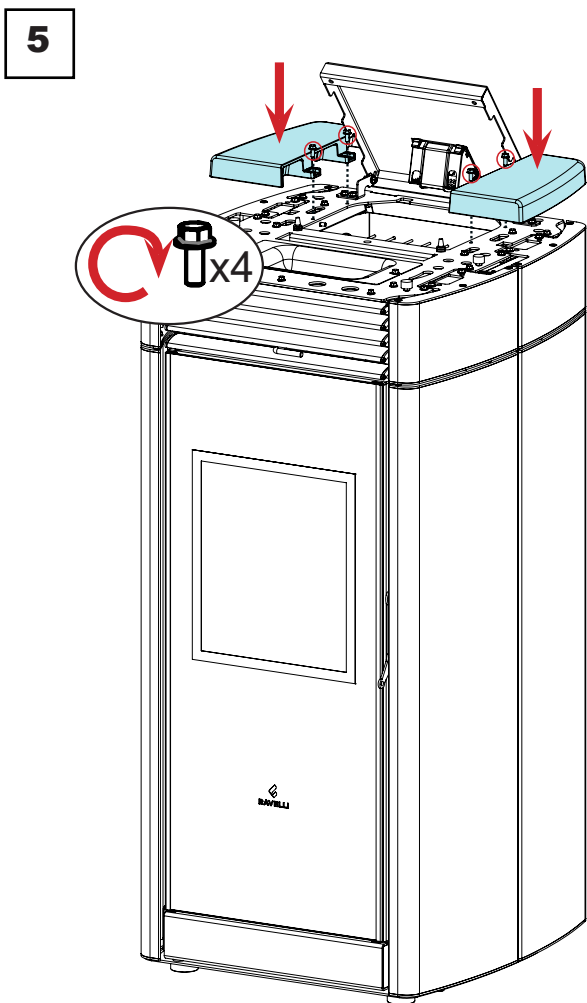
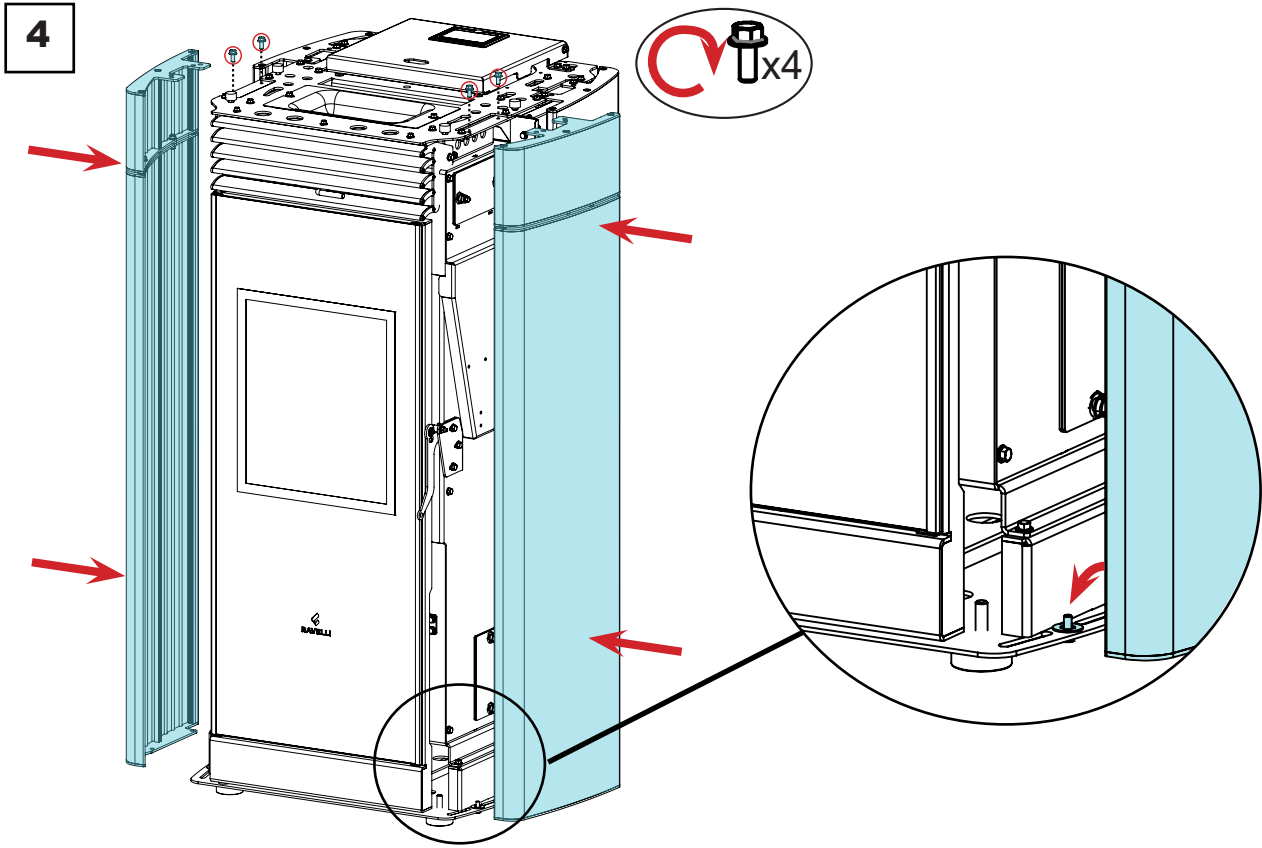

SHIPPING AND INSTALLATION

Safety warnings for transportation and installation



The stove must be installed by a qualified technician, who must issue a declaration of conformity of the system to the purchaser, taking full responsibility for stove installation and correct operation.



The stove installation site must be chosen so that the generated heat can spread evenly throughout the rooms that you wish to heat.



The stove needs to be connected to a single chimney that guarantees the draught declared by the Manufacturer and observes the installation regulations that apply to the installation site.



The room where the stove is installed must have an air intake.



The air vent must be installed in such a way that it can not be blocked.

The Manufacturer will not be held liable for installation that is not compliant with the laws in force, incorrect air circulation in the rooms and inappropriate use of the appliance.

In particular, it is necessary:

- that the appliance be connected to a smoke evacuation system duly sized to guarantee the draught declared by the Manufacturer, that is tight and observes the distances from flammable materials;
- that there is a suitable combustion air intake in compliance with the type of installed product;
- that other installed combustion appliances or devices do not create a vacuum in the room where the stove is installed;
- that the safety distances from flammable materials are observed.

Verification of system compatibility has a priority over any other assembly or installation operation.



Local administrative regulations and particular requirements of the authorities pertaining to the installation of combustion appliances, the air intake and the smoke evacuation system, may vary based on region or nation. Check with your local authorities if there are stricter laws than set forth herein.

Packaging

When the stove arrives, check:

- that it is the model you ordered;
- that it has not been damaged during shipping.

Any complaints must be reported to the deliveryman (also on the delivery note) upon receipt.



Check the capacity of the floor before handling and positioning the stove.

To handle the stove in its packaging, follow the procedure below:

- 1 Position the pallet truck forks in the slots under the wooden pallet.
- 2 Lift slowly.
- 3 Place the stove near the chosen location for installation.



The stove always needs to be handled vertically. Take extra care to protect the door and its glass against mechanical impact that could jeopardise their integrity

To unpack the stove, follow the procedure described below:

- 1 Cut the straps and remove the wooden reinforcement frame resting on the box
- 2 Slowly lift the cardboard box
- 3 Remove any bubble-wrap or similar
- 4 Remove the stove from the pallet and position the appliance in the chosen location, ensuring that it is compliant with the directions.

If the stove is packed in a wooden cage, replace steps 1 and 2 of the previous table with the steps described below:

- 1 Remove the side straps by unscrewing the fixing screws
- 2 Remove the upper and side wooden cage



The end user is responsible for disposing of the packaging in accordance with the laws in force in the country of installation.

Set-ups for the smoke evacuation system



Be careful when building the smoke evacuation system and observe the regulations in force in the country where the stove is installed.



The Manufacturer will not be held liable for incorrectly sized and non-regulation smoke evacuation systems.

Smoke ducts and fittings

The term smoke duct indicates all ducts that connect the combustion equipment to the chimney.

The following requirements need to be applied:

- observe product standard EN 1856-2;
- the horizontal sections must have a minimum slope of 3% upwards;
- the length of the horizontal section must be as minimum as possible, and its projection on the horizontal plane must not exceed 2 metres;
- changes in direction must not have an angle of more than 90° (45° bends are recommended);
- the number of direction changes, including the one necessary for insertion into the chimney, must not exceed 3;
- the cross section must have a constant diameter, the same from where it exits the firebox up to the fitting into the chimney;
- it is forbidden to use flexible metal and fibre cement pipes;
- smoke ducts must not cross rooms where the installation of combustion equipment is prohibited.

In any case, the smoke ducts must be sealed against combustion products and condensation, as well as insulated if they lead outside of the installation room.

Installing manual draught adjustment devices is not allowed.

Chimney

The chimney is a particularly important element for correct stove operation.



The chimney must be sized so as to guarantee the draught declared by the Manufacturer.



Do not connect the stove to a collective chimney.

The chimney must be built applying the following regulations:

- it must observe product standard EN 1856-1;
- it must be made of materials that are suitable to guarantee resistance against normal mechanical, chemical and thermal stress and be correctly thermally insulated to limit the formation of condensation;
- it must be mainly vertical and not feature any bottlenecks along its entire length;
- it must be correctly spaced with an air gap and insulated from flammable materials;
- there must be a maximum of 2 changes in direction and angles must not exceed 45°;
- the chimney inside the home, however, must be insulated and can be inserted into a skylight shaft, as long as it respects standards regarding placing inside a tube;
- the smoke conduit must be connected to the chimney using a "T" fitting with an inspection collection chamber for combustion residue and especially for collecting condensation.



It is necessary to check the safety distances that need to be observed when there are flammable materials and the type of insulating material that needs to be used is on the chimney data plate.



Use watertight pipes with silicone seals.



It is forbidden to use the discharge mounted directly on the wall or directed towards indoor spaces and any other type of discharge that is not set forth by the regulation in force in the country of installation (Note: in Italy only roof-discharge is allowed).

Chimney pot

The chimney pot, i.e. the top end of the chimney, must fulfil the following characteristics:

- the cross-section of the smoke outlet must be at least twice the internal cross-section of the chimney;
- it must stop water or snow from getting in;
- make sure the smoke is taken away even when there is wind (wind resistant chimney pot);
- the outlet height must be outside of the reflux zone (refer to national and local regulations to calculate the reflux zone);
- it must always be built at a distance from antennas or dishes, it must never be used as support.

Installation

 For appliance installation and use it is necessary to observe all of the local, national and European laws and regulations.

 Stove installation and the preparation of the building work must observe the regulation in force in the country of installation (ITALY = UNI 10683).

 The installation activities must be carried out by a technician that is qualified and/or authorised by the Manufacturer. The staff in charge of installation must issue a declaration of conformity of the system to the buyer, whereby they take full responsibility for the final installation and good operation of the installed product.

 Ravelli shall not be held liable if these precautions are not followed.

Requirements for the installation premises

The stove installation room must be sufficiently ventilated. To fulfil this requisite it is necessary to equip the room with an air intake connected to the outdoors.

 The installation room must have an air intake with a free cross-section of at least 80 cm².

 For installation in the presence of other combustion appliances or VMC system it is necessary to check the appliance for correct operation.

The stove must be placed inside living quarters. It must never be installed outdoors. The volume of the room where it is installed must be suitable for the power of the appliance and, in any case, greater than 15 m³.

 When extraction fans (example: extraction hoods) are used in the same room or space as the stove, this can cause problems to stove operation.

 The stove must be installed on a floor with suitable load capacity. If the existing position does not fulfil this requirement, it is necessary to take due measures (for example, using a load distribution plate).

 Provide due insulation if the surface is made of flammable material.

If the side walls adjacent to the stove are made of a flammable material, it will be necessary to position the stove at least 30 cm from them.

If the floor that the stove is standing on is flammable, we recommend duly insulating it. Objects and parts that are heat-sensitive or flammable cannot be stored near the stove; in any case, keep such objects outside the area bounded by the minimum distances indicated above.

Stove installation must guarantee easy access to clean the appliance, the exhaust ducts and the chimney.

Installation example for a stove/pellet stove

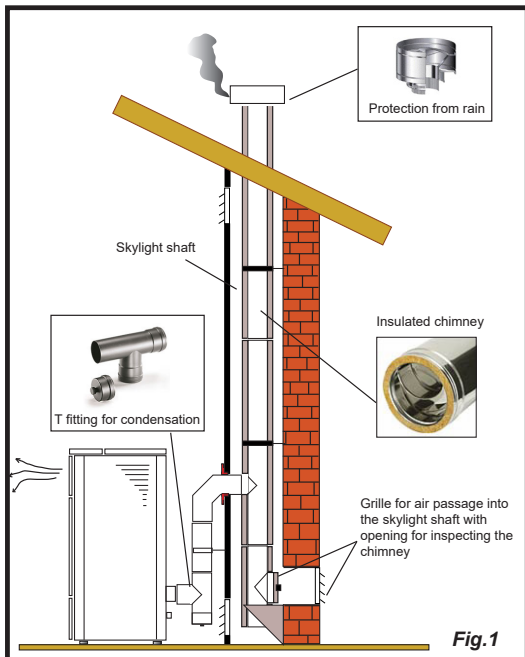

This type of installation (See Fig.1) requires an insulated chimney pot, even if the entire conduit is installed inside the building. Besides, the structure must be inserted into a properly ventilated skylight shaft.

In the lower part of the chimney pot there is an inspection cover, properly isolated from wind and rain.

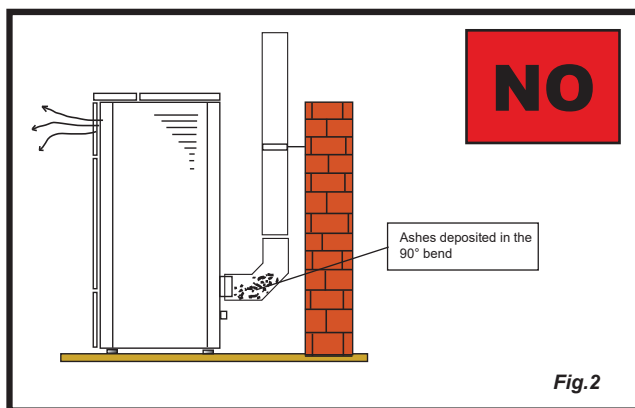

It is prohibited to install a 90° bend for the initial segment, since the ashes would quickly obstruct smoke passage, causing draught problems in the stove. (See Fig. 2)

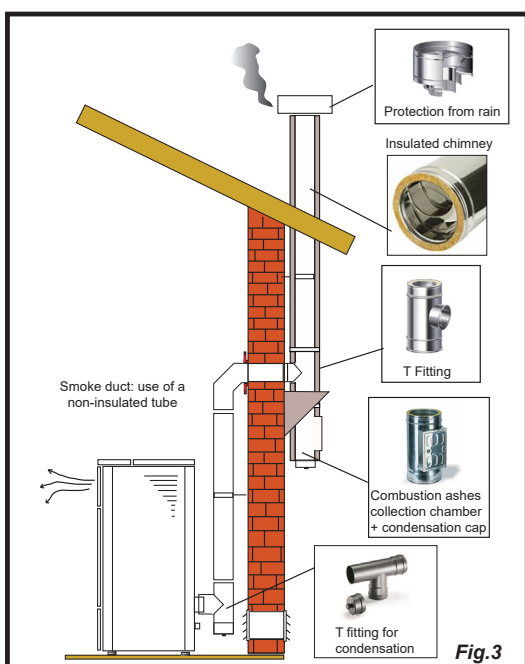

It is possible to use an existing chimney or a shaft via ducting. For this type of installation the standards on ducted smoke evacuation systems must be complied with. In the lower part of the chimney pot, inside the home, there is a "T" type fitting installed; externally there is another one installed, so that the outside section can be inspected.

It is prohibited to install two 90° bend, since the ashes would quickly obstruct smoke passage, causing draught problems in the stove. (See Fig. 2)

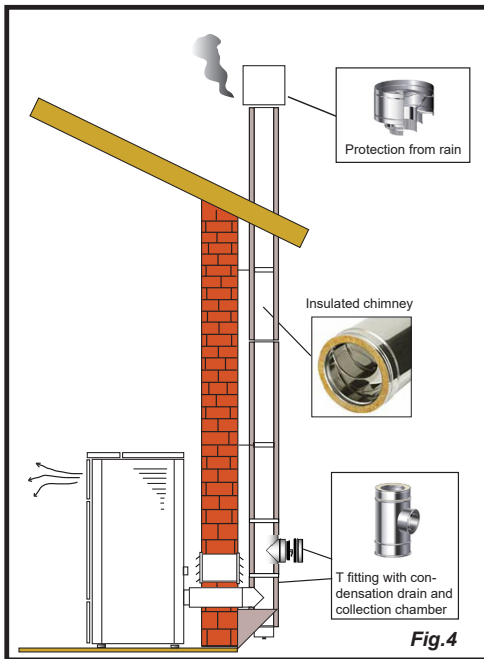

This type of installation (See Fig.4) requires an insulated chimney pot, even if the entire smoke conduit is installed outside the building.

In the lower part of the chimney there is a "T" type fitting installed with inspection cap.

It is prohibited to install a 90° bend for the initial segment, since the ashes would quickly obstruct smoke passage, causing draught problems in the stove. (See Fig.2)

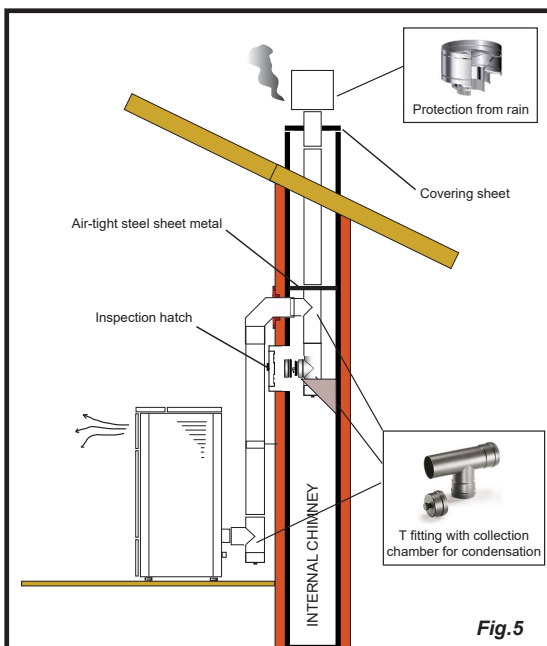

This type of installation (See Fig.5) requires an insulated chimney pot, since the entire smoke conduit is installed inside the building, and the part is located inside a pre-existing chimney pot.

In the lower part of the stove there is a "T" type fitting installed with inspection cap just like for the chimney pot.

It is prohibited to install a 90° bend for the initial segment, since the ashes would quickly obstruct smoke passage, causing draught problems in the stove. (See Fig.2)

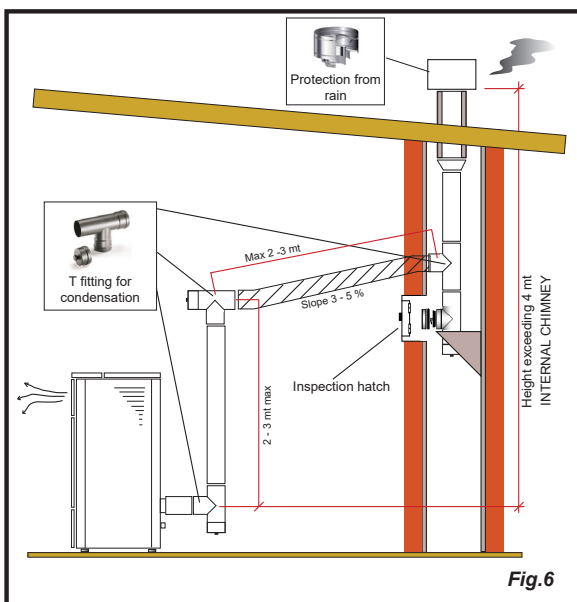

This type of installation (See Fig.6) requires a horizontal section to connect to a pre-existing chimney pot.

Respect the slope indicated in figure, in order to reduce the ashes depositing in the horizontal tube. In the lower part of the chimney pot, there is a "T" type fitting installed with inspection cap, in the same way as the chimney pot opening.

It is prohibited to install a 90° bend for the initial segment, since the ashes would quickly obstruct smoke passage, causing draught problems in the stove. (See Fig.2)

CONNECTIONS



The connections must be set up by a technician that is qualified and/or authorised by the Manufacturer.



By the installer the type of cable, with relative section, to be installed in case of replacement is: H05RR-F sez.3G0,75

Connection with external air intake

The stove has been designed for hermetic installations.

To make the connection with an external air intake, proceed as follows:

step	action
1	Connect a 50 mm diameter pipe to the combustion air inlet pipe at the back of the stove. Note: the pipe must be no more than 2 m in length.



The air vent must be installed in such a way that it can not be blocked.

Chimney connection



The chimney must be sized so as to guarantee the draught declared by the Manufacturer.



The stove must be connected to a single flue. It is forbidden to connect the stove to a flue shared with other combustion appliances or with hood exhausts.



The flue must be inspectable for cleaning.

Electrical connection

The plug of the stove's power cable must only be connected after the installation and assembly has been completed of the appliance, and must remain accessible after installation.

To make the electrical connection, proceed as described below:

First connect the power cable to the plug on the back of the stove and then to a wall socket.

Supply power to the stove by turning the switch to position (I).



When the stove is not in use, it is advisable to disconnect the power cable.



Take care that the power cord (and any other cables outside the equipment) do not come into contact with hot surfaces.



Ensure that the electrical system is grounded.



For direct connection to the mains, it is necessary to provide a device that ensures disconnection from the mains, with a contact opening distance that allows complete disconnection under the conditions of overvoltage category III, in accordance with installation rules



If the power supply cable is damaged, it must be replaced by the manufacturer or its technical assistance service or in any case by a person with similar qualifications, so as to prevent any risk.



It is recommended that authorized personnel pay special attention to the electrical connections after any work on the product.

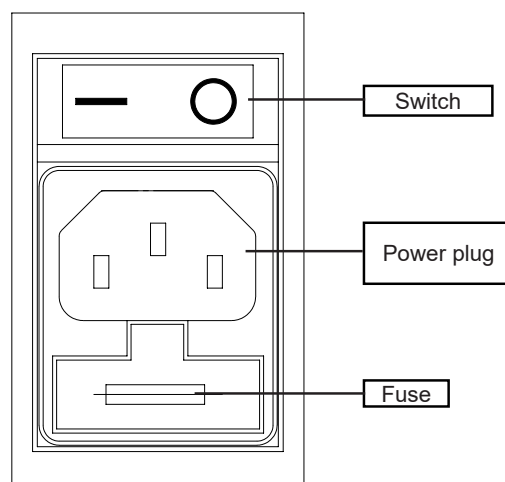

Connection of external thermostat

To manage the stove using an external thermostat (optional), connect it to the appropriate "TERM" terminals on the board, as shown in the Electric scheme.



Connect an open/closed external thermostat, therefore potential-free.

Testing and commissioning

Stove start-up must be preceded by testing, which includes an operational check of the following elements:

- connection to the smoke evacuation system;
- electrical connections;
- operation of any connected external probes;
- checking that all materials used to build the smoke duct, chimney and chimney pot are regulation and suitable for use.

The testing is positive only when all operational phases have been completed without any anomaly being detected.

Electric scheme RV 100

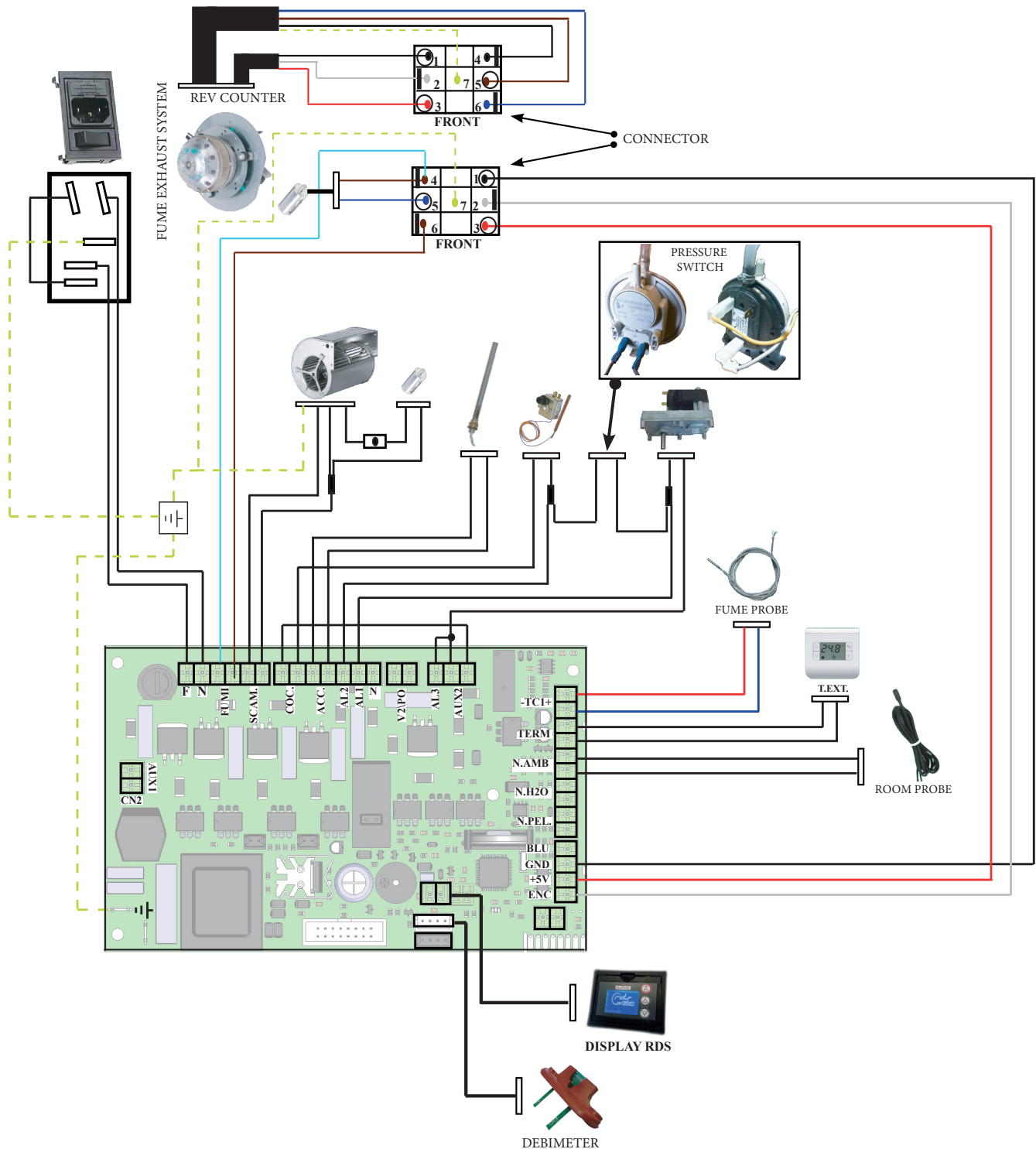

DESCRIPTION OF THE FUNCTIONING AND SYMBOLOGY OF THE DISPLAY

The display of the handheld set is described below (in "Home" mode):

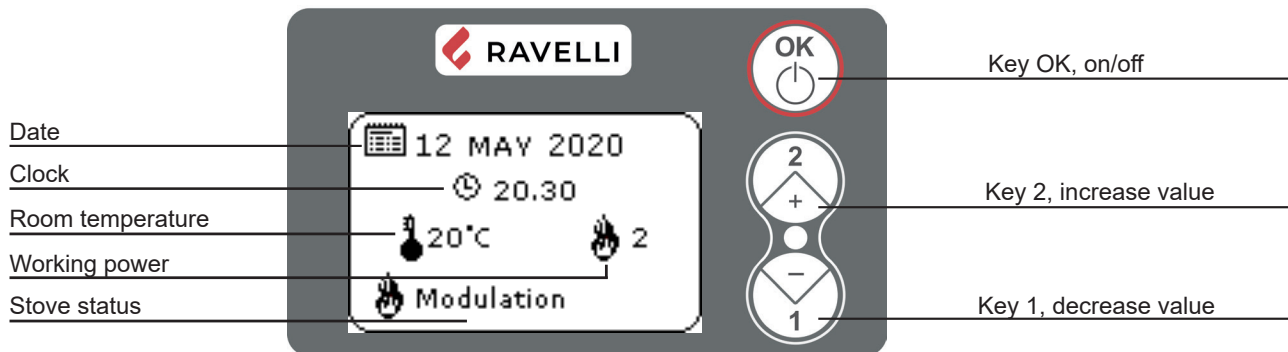

Key "OK": in the Home screen, long press to turn the appliance on / off or reset the alarms; short press to enter the menu

Key "1": access key to "set room temperature" and regulation (decrease value)

Key "2": access key to "set power" and regulation (increase value)



The first press of any key with active display turns on its backlight, not interpreting it as a command.

PROCEDURES FOR USE



If the chimney catches fire you must call the fire brigade immediately.

Checks prior to start-up



You have read and perfectly understood the contents of this instructions manual.

Before lighting the stove, you must ensure that:

- the combustion chamber is clean;
- the fire door and ash drawer seals are functioning properly;
- the electrical plug is connected correctly;
- all items that could burn (instructions, various adhesive labels) have been removed;
- the fire pot, if removable, is correctly positioned in its housing.



During the first hours of use the paints used for the stove finish may release an unpleasant odour. You might also smell the typical odour of metal parts subject to high temperatures. Make sure sufficient air circulation is guaranteed in the room. These unavoidable inconveniences will disappear after the first hours of operation. To reduce your discomfort to a minimum, keep the stove on for a few hours on low power and in the beginning, do not overload it, avoiding intense heating-cooling cycles



At the initial start-up, the paint finishes drying and hardens. Accordingly, to avoid ruining it, we advise you not to touch the stove's painted surfaces at this time.

Pellet auger loading

Before starting the stove for the first time, whenever the stove is in alarm "06 - Pellets finished", and in any case whenever the hopper has emptied completely, the initial auger loading is required.

This phase allows the stove to fill the pellet loading system (the system that carries the pellets from the tank to the fire pot), so that at the time of ignition, the pellets can be loaded into the fire pot and then the stove can be ignited. If the auger loading operations are not carried out, the stove could fail to ignite.

To load the auger, follow the instructions given in the paragraph "Stove status menu".



After loading the auger and before lighting the stove, always remember to empty the fire pot and check that the fire pot is clean. Never empty the fire pot inside the hopper.



After each maintenance operation, make sure that the fire pot is positioned correctly in its seat.

Switching the appliance on and off

From the "Home" screen, it is possible to switch the stove on and off by keeping the OK button  pressed on the device for a few seconds. An acoustic signal will warn you that the appliance has switched on or off.



Do not turn off the stove by disconnecting the electric plug from the wall socket.



The appearance of the "SET RDS" message indicates that the initial parameter testing and calibration procedure was not carried out correctly. This indication does not imply blocking the stove (see SIGNALING POP UP section).

Failed ignition

If the system does not detect the ignition of the flame within the preset time, operation will be blocked with the "No ignition" alarm. Before relighting the stove, check that there are pellets in the hopper, that the door and ash drawer compartment are closed, that there are no obstructions to the combustion air inlet system and above all that, in models without self-cleaning fire pot, the fire pot is empty, clean and correctly positioned. If the problem persists, it could be due to a technical problem (ignition plug, adjustments, etc ...), so please contact a Ravelli CAT.



The accumulation of unburned pellets in the fire pot after a failed ignition must be removed before proceeding with a new ignition.



The fire pot could be very hot: danger of burns



Never empty the fire pot inside the hopper.

Set of the room temperature

The functioning of the stove with room thermostat activated is of 3 types:

- With supplied room sensor positioned on the backside of the stove
- With room sensor integrated to the display (recommended for use with wall mounted display only)
- With external thermostat

Press key 1 from the "Home" screen to enter the room temperature setting page

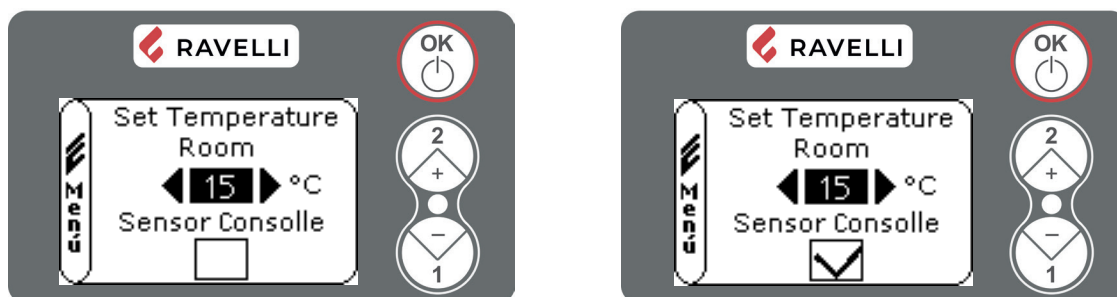

Set the desired temperature with keys 1 and 2. The selectable values are: EST, from 7 °C to 40 °C (or from 44 °F to 104 °F), MAN. The EST value must be selected if you want to use the external thermostat and MAN when you want to make the stove work at constant power.

To go back directly to the "Home" screen, press keys 1 and 2 at the same time, or press OK to go to "Console probe".

By enabling the "Console probe" function, the temperature reading with the ambient probe integrated in the display is enabled. Enable the function with key 2 and disable it with key 1. To return to the Home screen, press OK

If you use an external thermostat correctly connected as shown in the electrical scheme, the display will not show the room temperature but the writing T ON (when the contact is closed) or T OFF (when the contact is open).

To use the external thermostat, the "console probe" must be deactivated.

The room temperature will be adjusted by the external thermostat.

Once reached the set temperature of the thermostat the display will show MODULATION, so the stove will reduce to minimum the pellet consumption and the power as well. If activated the mode COMFORT CLIMA, the stove will switch on and off automatically.

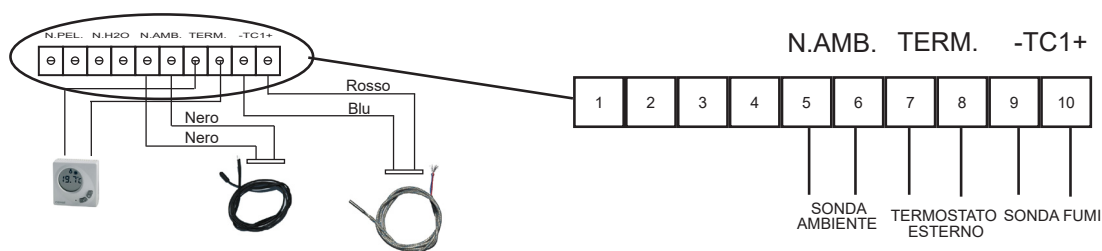

If you want to use the COMFORT CLIMA is advisable an external thermostat with OFF-SET of at least 3°C.

Set of the working power

To modify the working power press key 2 to enter in the dedicated menu and with keys 1 and 2 to set the power you desire from 1 to 5 and confirm with key OK. Increasing the power also the pellet consumption and the speed of the fan increase as well.

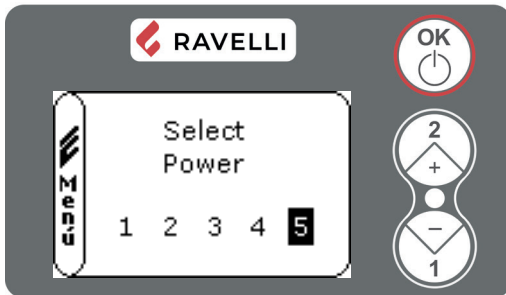

OPERATING PHASES OF THE APPLIANCE

Sequence of ignition phases

During the ignition phase, the following indications will appear on the display:

- IGNITION: loading phase of the pellets in the fire pot and heating of the ignition electrode (variable waiting time according to the factory parameters)
- WAITING FLAME: flame ignition waiting phase (variable waiting time depending on the factory parameters)
- FLAME LIGHT: phase of development and stabilization of combustion (waiting time varies depending on the factory parameters)
- WORK: normal operating mode, according to the chosen settings

If the ignition command is given when the stove is still hot, i.e. in FINAL CLEANING, the stove will remain in the WAITING RESTART phase for a few minutes, after which it will automatically re-ignite (IGNITION RESTART).

Modulation

During the work phase, the appliance should reach the room temperature set; when this condition is met, the stove switches to MODULATION mode in which fuel consumption is minimum.

Description of menu functions

To access the menu from the "Home" screen, press the OK button (short press).

To scroll the menu list, use buttons 1 and 2 and then confirm with OK to enter the submenus.

Then, to return to the "Home" screen, press keys 1 and 2 at the same time. To return to the previous menu, press OK (long press).

The stove is equipped with many functions available in each menu programming. Some of these menu are accessible for the end user, other are protected with a password so they are accessible only for the After sales center.

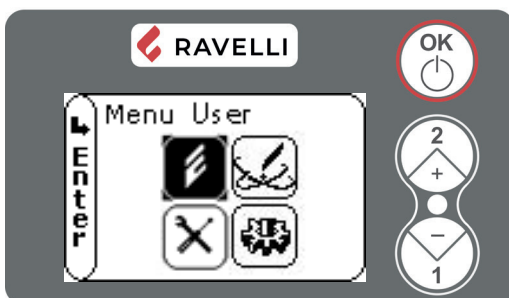

- Menu USER
- Menu SET RDS
- Menu DEFAULT SETTINGS
- Menu STANDARD PARAMETERS



The SET RDS, DEFAULT SETTINGS, and STANDARD PARAMETERS menus are password protected. Changing parameters within these menus could compromise the operation and safety of the stove. In this case the warranty will be invalidated.

The submenus of the USER MENU (the only one accessible for the end user) are the following:

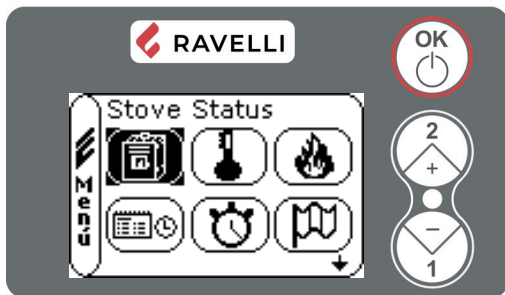

- Menu STOVE STATUS
- Menu SET TEMPER. ROOM
- Menu SET POWER
- Menu CLOCK
- Menu TIMER
- Menu LANGUAGE

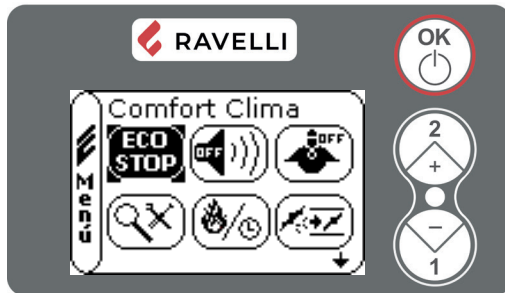

- Menu COMFORT CLIMA
- Modalità SILENCE
- Modalità SELF CONTROL SYSTEM
- Menu VIEW SETTINGS
- Menu VIEW WORKING HOURS
- Menu SET DRAUGH/PELLET

Menu STOVE STATUS

In this menu you can check the correct functioning of the most important components of the stove. Here is a list of real data of the stove useful for service during inspection.

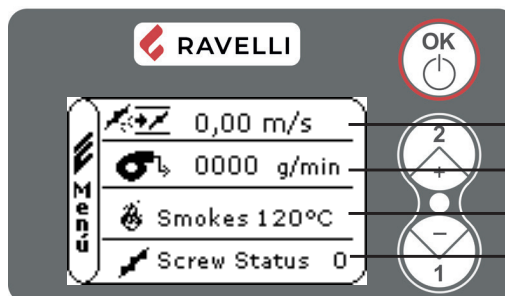

Speed inlet flow
Rpm smoke fan
Smokes temperature
Screw status

 RDS current reading RDS (m/s)

 RPM current smoke extractor speed (rpm)

 Smokes temperature (°C)

 Screw status

SET Set value RDS (m/s)

DF Cold probe temperature RDS (°C)

DR Hot probe temperature RDS (°C)

SK Electronic board temperature (°C)

To go to the second screen, press key 1.

From the first screen it is possible to activate the initial loading of the auger by pressing key 2. The Screw Status value will become 1.

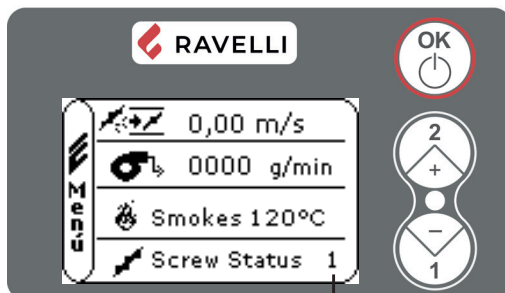

Screw ON

The initial load will stop automatically after a pre-set time, to stop it first press key 2.

Repeat the operation several times until you see the pellet fall into the firepot. It is possible to do this operation only if the stove is in FINAL CLEANING phase or OFF.

Menu SET TEMPERATURE ROOM

To modify the setting please reference to paragraph "Set of the room temperature"

Menu SET POWER

To modify the setting please reference to paragraph "Set of the working power"

Menu CLOCK

To modify the settings use keys 1 and 2 and by pressing OK you confirm the data and go on to the following one. By activating the box (flag) ON/OFF you enable the function chrono.

By last confirmation with OK you save all settings and return automatically to the screen with the icons.

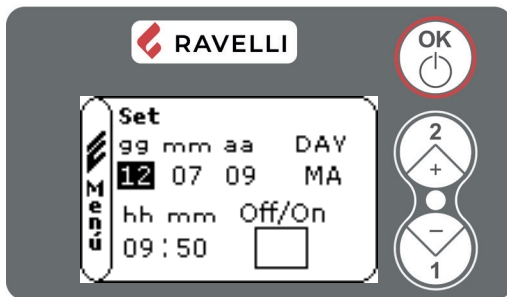
Menu TIMER

With the function chrono thermostat is possible to program for each day of the week the switch on and off of the stove in four independent intervals time. To enable the TIMER, see what is reported in the Clock menu.

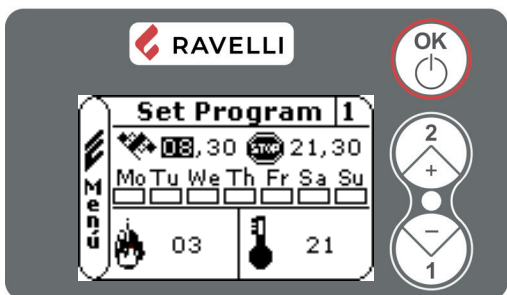

1 TIMER program number



START: switch on time



STOP: switch off time



DAY: days of activation of the program



POWER: desired power at the time of switch ON of the stove



TEMPERATURE: setting of ambient temperatures

In ducted stoves it is possible to set the temperatures of the individual rooms:

F (front) temperature of the stove installation room

R (Rear, single duct) room temperature heated by ducting

RL and RR (Rear Left and Rear Right for double ducting)

The EST (operation with external thermostat) and MAN (constant power operation) values can also be set

To choose the prog.tion use keys 1 and 2; confirms with OK.

Use keys 1 and 2 to modify the settings and by each press of OK you confirm the data and go on to the following one.

By last confirmation with OK you save all settings and return automatically to the screen with the icons.

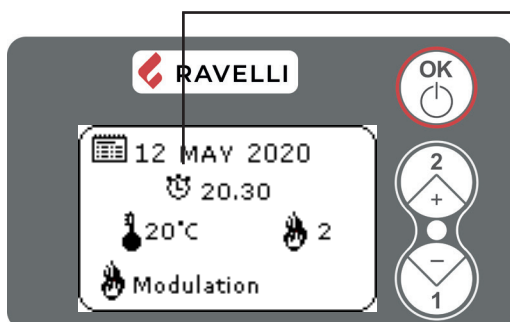

The symbol indicates that the chrono function is active. It is however possible to program the chrono even if it is deactivated. To make it work, refer to the chapter dedicated to setting the clock.

Description

Description	Settable values
START	From OFF to 23:50 by step of 10'
STOP	From OFF to 23:50 by step of 10'
DAY	On/off for the days from Monday to Sunday
POWER	From 01 to 05
SET AMB.	From EST to MAN

Examples

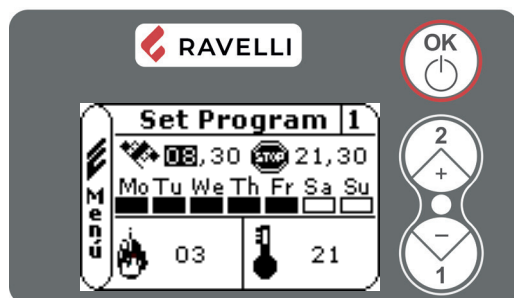

Activation days: Monday to Friday
 Switch on at 8.00
 Switch off at 21.30
 Power: 3
 Room temperature: 21°C

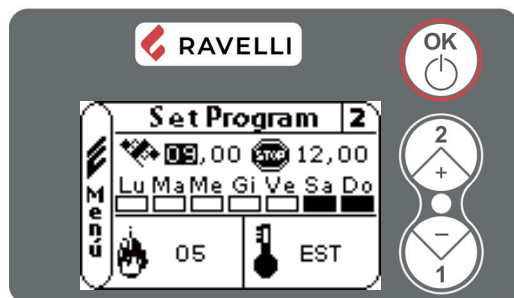

Activation days: Saturday and Sunday
 Switch on at 9.00
 Switch off at 12.00
 Power: 5
 Room temperature: Regulated by an external thermostat

The Comfort Clima function also works with the Timer active.



By using this mode it is necessary to check that after every automatic switching off the firepot is always well cleaned in order to guarantee a perfect automatic ignition.

Menu LANGUAGE



To select language please use keys 1 and 2.

By last confirmation with OK you save all settings and return automatically to the screen with the icons.

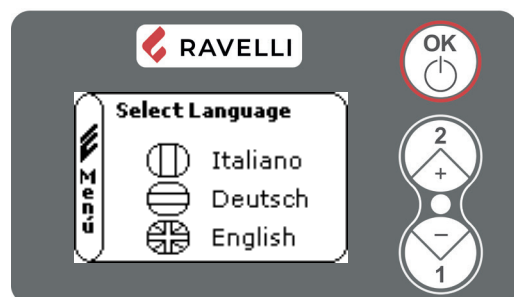

Menu COMFORT CLIMA

To modify the settings use keys 1 and 2 and by pressing OK you confirm the data and go on to the following one. By last confirmation with OK you save all settings and return automatically to the screen with the icons.

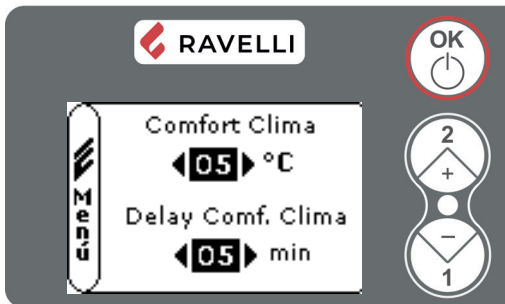

The activation of this function enables the stove to reduce pellet consumption by activating the modulation phases, after the desired temperature has been reached. Subsequently, the stove checks that the temperature is maintained steady for a preset time (DELAY COMFORT CLIMA). If this condition is met, it automatically switches off, and on display appears the writing ECO STOP. The stove turns on again when the temperature drops below the set threshold (COMFORT CLIMA).

Below are given the steps for accessing the relative menu.

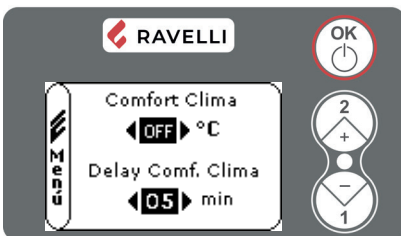
Example

To activate the function, set the COMFORT CLIMA value different from OFF using buttons 1 and 2. Confirm with OK. Set the time in which the stove must remain in MODULATION, before switching to ECO STOP (default 4 ').

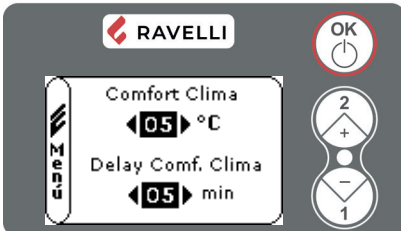

The set value (in this case 5 ° C) activated the Comfort Clima function.

OPERATION:

The value adjusts the re-ignition temperature of the stove.

EXAMPLE:

- room temperature set at 21 ° C
- Comfort Clima value set at 5 ° C

With this adjustment, the stove will switch off when it reaches 21 ° C and will switch on again when the room temperature is 15 ° C ($21\text{ ° C} - 5 - 0.5\text{ tolerance} = \text{about } 15\text{ ° C}$). The strings shown in the screens on the left will appear in sequence on the display.

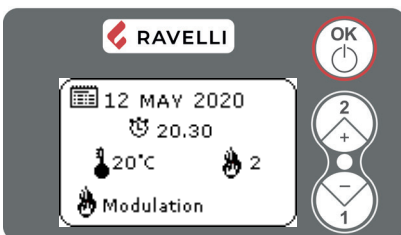

The modulation phase is activated, as the room set temperature has been reached. If the temperature is maintained for the set "DELAY COMFORT CLIMA" time, the stove switches off.

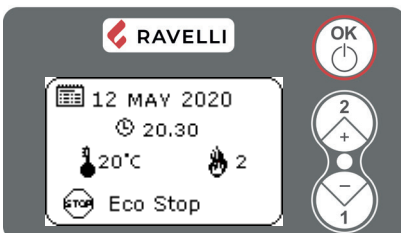

Once the switch-off phase is complete, the display will show ECO STOP. The stove will remain in this state until the temperature drops to 15 ° C, only then will the ignition phase be restarted.



The operation of the stove in COMFORT CLIMA mode can start the ignition and shutdown phase several times during the day; this can compromise the duration of the resistance for automatic stove ignition.



Using this mode, it is necessary to make sure that after each automatic switch-off, the fire pot always remains perfectly clean in order to guarantee correct automatic ignition. The COMFORT CLIMA mode also works with an external thermostat connected.

Mode SILENCE

Enable or disable the function by using key OK.

Mode SILENCE has been realized for reducing noise level of fan. It reduce the speed of the fan in all five working power. Use is suggested especially during night time.

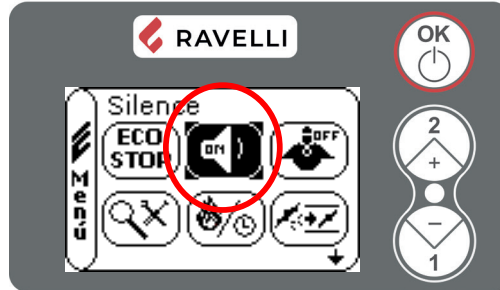
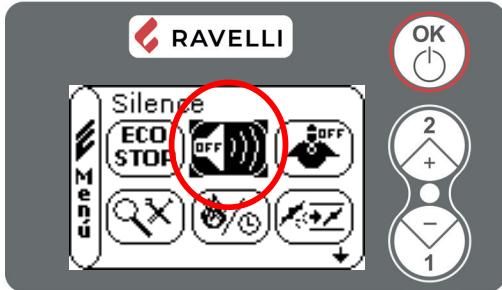
Mode SELF CONTROL SYSTEM (S.C.S)



Enable or disable the function by using key OK.

Mode SELF CONTROL SYSTEM (S.C.S) has been realized allowing the stove to recognize faster an eventual problem just in case you are out of home or far from the stove.

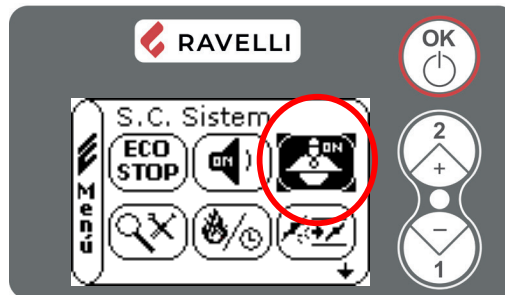
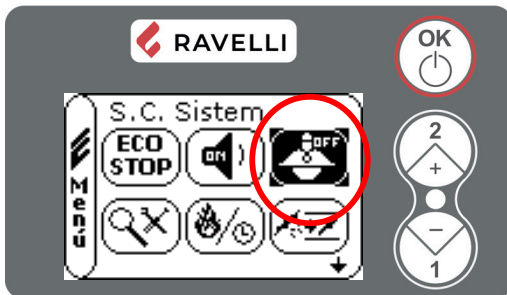
It is advisable to activate this function especially if you are not in the vicinity of the stove during work phase.

Menu VIEW SETTINGS

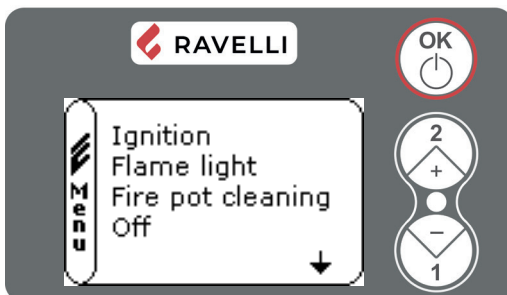

In this menu you can verify the parameters set in the motherboard.



To scroll the list of parameters use key 1 and 2, to view the parameters press OK.

Menu VIEW WORKING HOURS

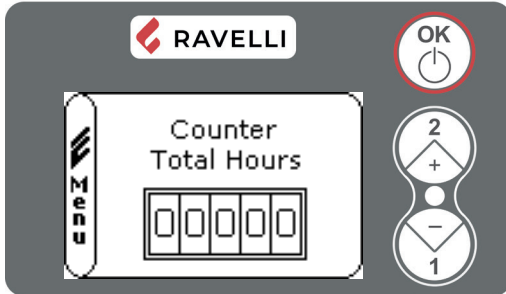
In the menu VIEW WORKING HOURS you can check the total or partial working hours and also the number of ignitions of the stove. This menu is used by the After Sales Center to evaluate the total working hours of the stove during the season and consequently to evaluate the need of cleaning ("service hours").



You can see the working hours of the stove. To scroll the different counters (total or partial hours and number of ignitions) use key 1 and 2.

Menu SET DRAUGH/PELLET

This setting of the PELLETT-FLOW mixture allows to adjust the combustion by varying the quantity of pellets loaded in the fire pot and/or the quantity of air. Infact, by its nature, pellets vary in grain size and composition: even bags of pellets of the same brand can have different characteristics. If combustion is not optimal, vary the flow parameter to adjust the combustion air. If air regulation alone is not sufficient, it may also be necessary to modify the pellet parameter.



Combustion regulation is an operation that requires a lot of experience. We recommend that you contact an Authorised Service Centre to calibrate the stove appropriately.

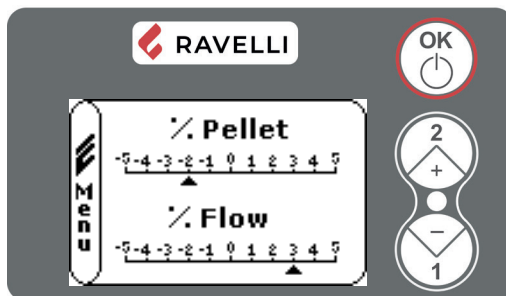

By accessing the menu, the adjustment of the draft / pellet mixture is displayed. To change the percentage use buttons 1 and 2, to switch from adjusting the quantity of pellets to adjusting the inlet air flow, press OK.

At the last confirmation with OK, the settings are saved and you automatically return to the icons screen.

Service hours

All our models need in addition to the regular cleaning, also a special cleaning which should be done by the installer (authorized by the producer).

At the time of the installation it is possible to set a number of working hours appropriate for the model. At the end of these hours on the display will appear the message "SERVICE HOURS" followed by an acoustic signal. When this message appears please contact the installer to do the special cleaning of the stove.

If the cleaning is not done the message will appear by each ignition but will not interrupt the functioning of the stove.

Remote control

Infrared handheld device for remote control

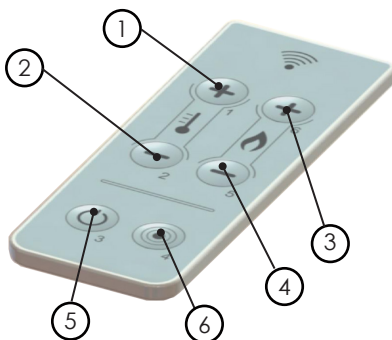

- **1 - 2 Set temperature:** allows to set the desired value for the room temperature from minimum 6 °C to maximum 40 °C (or from 44 °F to 104 °F).
- **3 - 4 Set power:** allows to set the working power between a range of minimum 1 to maximum 5.
- **5 ON/OFF:** by keeping pressed for 2 second longs it allows the manual switch on and off of the stove
- **6 Without function**

Stove phase general layout

Phase	Description
FINAL CLEANING	The stove is switching off, the cooling phase is not yet completed
IGNITION	The ignition phase has started, the pellets are loaded into firebox
WAITING FLAME	The pellet is lighted by the hot air passing through the ignition candle
FLAME LIGHT	The flame is visible in the fire pot
WORK	The stove completed switch ON phase; you can change power
FIRE POT CLEANING	The stove is performing the cleaning
MODULATION	The room temperature set has been reached
ECO STOP	Comfort Clima activated, temperature set has been reached; the stove is off.
T ON / T OFF	The room sensor is off or an external thermostat has been connected and the room set is set to EXT
WAITING START	The stove is cooling DOWN: when stove is cooled down can start automatically
WAITING RESTART	The stove is in the cooling DOWN: when stove is cooled down can restart automatically.
HOT SMOKES	The maximum fume temperature threshold has been reached. To facilitate cooling, the stove brings the capacity to a minimum with ventilation at max power level
OFF	The stove is off
ANOMALY (general)	The stove has detected an anomaly; refer to the troubleshooting chapter.

Description of alarms

AL	Warning	Reason	Solution
AL 01	BLACK - OUT	No electricity supply during working phase	Press the off button and repeat switching on the stove
			If the problem continues, contact the area Technical Assistance Centre.
AL 02	SMOKE SENSOR	The smoke sensor is malfunctioning	Please contact the local Technical Assistance Centre
		The smoke sensor has been disconnected from the board	Please contact the local Technical Assistance Centre
AL 03	HOT SMOKE	Combustion in the fire pot is not optimal	Switch off the stove, clean the fire pot and regulate combustion with the setting of the pellets.
		The centrifugal fan is defective	Contact local Technical Assistance Centre.
			If the problem continues, contact the area Technical Assistance Centre.
AL 04	FAN BROKEN	Smoke extractor encoder is not functioning or not correctly connected	Contact local Technical Assistance Centre.
		No electricity supply to smoke extractor	Contact local Technical Assistance Centre.
		The smoke extractor is blocked	Contact local Technical Assistance Centre.

AL	Warning	Reason	Solution
AL 05	NO IGNITION	The pellet tank is empty.	Check if there are pellets inside the tank.
		Setting of pellets and of intake during ignition phase insufficient.	Contact local Technical Assistance Centre.
		The resistance for lighting is defective or not in position	Contact local Technical Assistance Centre.
AL 06	NO PELLETS	The pellet tank is empty	Check whether there are pellets in the tank
		The ratiomotor does not load pellets.	Empty the tank to check that no objects have fallen inside which could prevent the correct functioning of the auger
		No pellet loading	Regulate the pellet setting
			If the problem continues, contact the area Technical Assistance Centre.
AL 07	THERMAL ALARM WITH RESET	The thermostat with manual reset has intervened	Reset the thermostat pressing the button on the back of the stove
		The centrifugal fan is defective	Please contact local Technical Assistance Centre.
		Combustion in the fire pot is not optimal	Switch off the stove, clean the fire pot and regulate combustion with the setting of the pellets.
			If the problem continues, contact the area Technical Assistance Centre.
AL 08	DEPRESSION	The combustion chamber is dirty	Follow the cleaning operations of the stove as per the instructions in the booklet
		The flue is blocked	Check that the flue is clear and clean
		The vacuum switch is malfunctioning	Please contact local Technical Assistance Centre
AL 09	AIR-FLOW METER	The device who read the quantity of inlet air could be disconnected or defect	Please contact the local Technical Assistance Centre
		The device could be dirty and so not read correctly	Please contact the local Technical Assistance Centre
AL 11	LOW FLAME	The pellet tank is empty.	Check whether there are pellets in the tank
		Bad setting of pellet and air on ignition in phase	Contact local Technical Assistance Centre
AL 12	FAN RPM	The revolution of smoke fan lowering more the 15% of speed to fan congestion	Contact local Technical Assistance Centre
AL 13	INSUFFICIENT FLOW	The door and the ashtray are not correctly closed	Check the devices are closed
		Bad combustion in the fire pot	Switch off the stove, clean the fire pot, the grid and set the combustion through the set pellet/flow.
		Presence of a foreign body inside the air inlet pipe	Check for its presence and extract the unwanted body
			Please contact the local Technical Assistance Centre
AL 14	AUGER PHASE	The gear motor is not correctly connected	Please contact the local Technical Assistance Centre
AL 15	AUGER TRIAC	The device in the motherboard who gears the auger is defect	Please contact the local Technical Assistance Centre



AL 09 - AIR-FLOW METER is an alarm that do not block the operation of the stove. In these conditions, the stove goes into modulating work, working at fixed extractor revolutions (RDS off). In any case, a periodic visual and acoustic signal indicating the type of problem remains active. Please contact the local Technical Assistance Centre.

To reset the alarm, keep the OK key pressed for a few seconds. The stove can be restarted manually or automatically (in the case of an active chronothermostat or external thermostat) only after resetting the alarm.

MAINTENANCE

Safety warnings for maintenance

! Maintenance of the stove must be performed at least once a year and should be planned in advance with the Technical Assistance Service.

! In some conditions, such as turning the stove on and off or inappropriate use, the combustion products can contain small soot particles that build up in the smoke evacuation system. This can reduce the cross-section of the smoke duct and pose a fire risk. The smoke evacuation system must be inspected and cleaned at least once a year.

! The maintenance operations must be carried out when the stove is cold and with the electrical power supply disconnected.

Before completing any maintenance operation, adopt the following precautions:

- Make sure that the power supply plug is disconnected.
- Make sure that all stove parts are cold.
- Make sure that the ashes are completely cold.
- Always operate with equipment that is appropriate for maintenance.
- When maintenance is finished, re-install all of the dis-assembled parts before restarting operation.

 The quality of the pellet, the stove operating mode and combustion control can affect maintenance activity frequency.

Cleaning

 Perform the cleaning operations so as to guarantee correct stove operation.

The table below lists the necessary cleaning operations required for correct stove operation.

PARTS / FREQUENCY	1 DAY	2-3 DAYS	30 DAYS	60/90 DAYS
Brazier	•			
Ash drawer		•		
Glass		•		
Scraper		•		
Combustion chamber			•	
Pellet tank			•	
Extraction duct				•

 In the first periods of use, carry out cleaning operations frequently to understand the right frequency of intervention, which varies according to the installation, use, pellet used, etc.

Brazier cleaning

It is necessary to check that the brazier where combustion takes place is well cleaned and that slag or residues do not obstruct the holes. This precaution will ensure excellent combustion, avoiding the failed ignition of the stove.

Cleaning must be carried out daily, before each ignition. For a small cleaning, you can leave the brazier in the stove, but if the residues are difficult to remove, you have to take it out of its housing and scrape the slag.

The quantity and consistency of the ash residue depends on the quality of the pellets used.

! After each maintenance operation, make sure that the brazier is positioned correctly in its seat.

Cleaning the ash drawer

The ash drawer must be cleaned every 30 days, (depending on the amount of time the stove is used and what type of pellet is used).

To clean the ash drawer, proceed as follows:

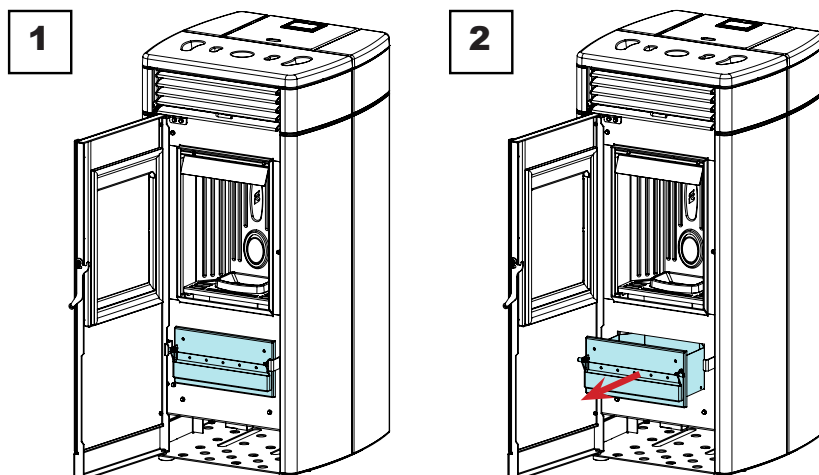

Glass cleaning

With a cold stove, clean the glass with a cloth and glass cleaner.

Note: there are stove glass cleaning products available on the market.

Cleaning the tube heat exchanger

During operation, dust and soot are deposited on the surface of the heat exchanger tubes. To ensure smooth operation throughout the season, it is advisable to periodically clean the heat exchanger when the stove is cold. Using the cold handle, extract the scraper rod and firmly move the scraper back and forth.

Once you have finished cleaning the exchanger, push the scraper into the grille (never leave it removed).

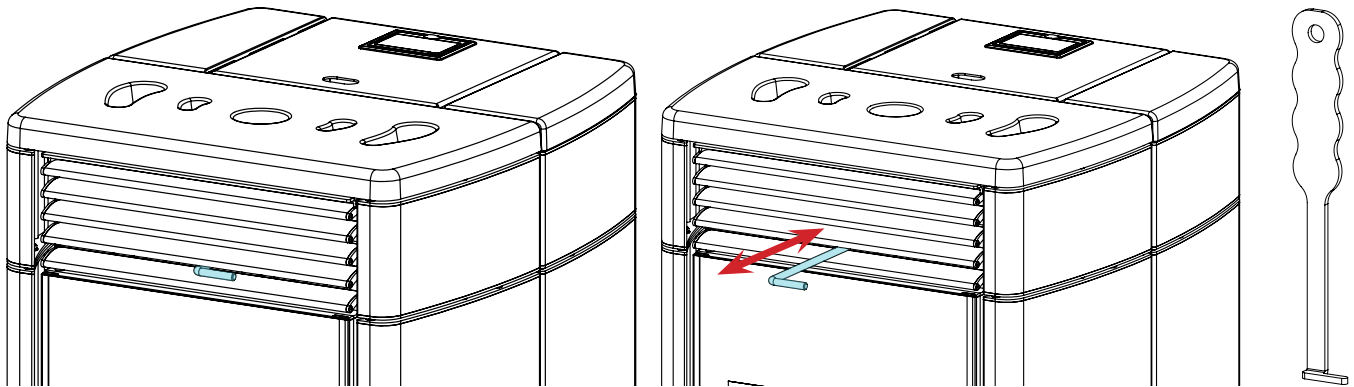

Combustion chamber cleaning

To clean the ash drawer, proceed as follows:

step	action
1	The stove requires a simple yet frequent cleaning in order to guarantee suitable yield and regular operation. Vacuum the combustion chamber every day using a bin ash vacuum, making sure that the ashes are completely cold.

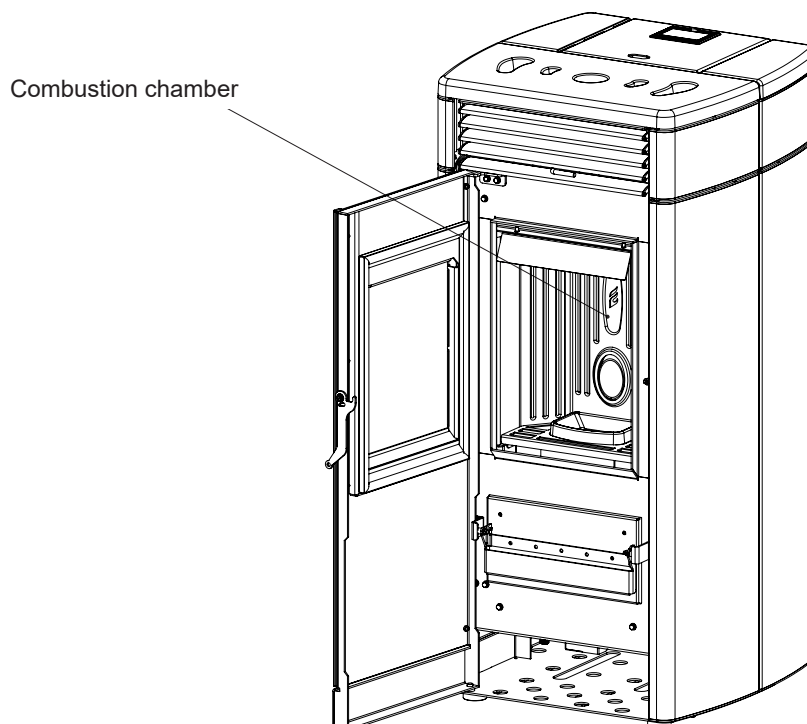

Cleaning the pellet tank



To clean the pellet tank, proceed as follows:

step	action
1	Periodically remove the wood sawdust accumulated on the bottom of the tank, using a vacuum cleaner.

Extraction duct cleaning

Periodically check that the extraction duct is free from obstructions (dust, animal hair ...) and remove them if necessary.

Extraordinary maintenance

-  Maintenance operations must be carried out with the stove cold and with the power supply disconnected.
-  Extraordinary maintenance activities must be carried out by staff from the Authorised Assistance Centre.
-  Do not wait for components to be deteriorated by use before proceeding with their replacement. Replace a worn component before it is completely broken to prevent any damage caused by sudden component breakage.

PARTS / FREQUENCY	1 SEASON
Deep combustion chamber cleaning	•
Door gasket	•
Chimney	•
Smoke conduit	•

Schedule the above extraordinary maintenance activities with the Authorised Assistance Centre.

Deep combustion chamber cleaning

 This operation must be carried out by a Ravelli Assistance Centre.

 Schedule this type of cleaning with the Ravelli Assistance Centre.

To clean the combustion chamber, proceed as described below:

After cleaning the combustion chamber, it is advisable to proceed with the cleaning of the inspection hatches as indicated in the paragraph "Smoke duct cleaning".

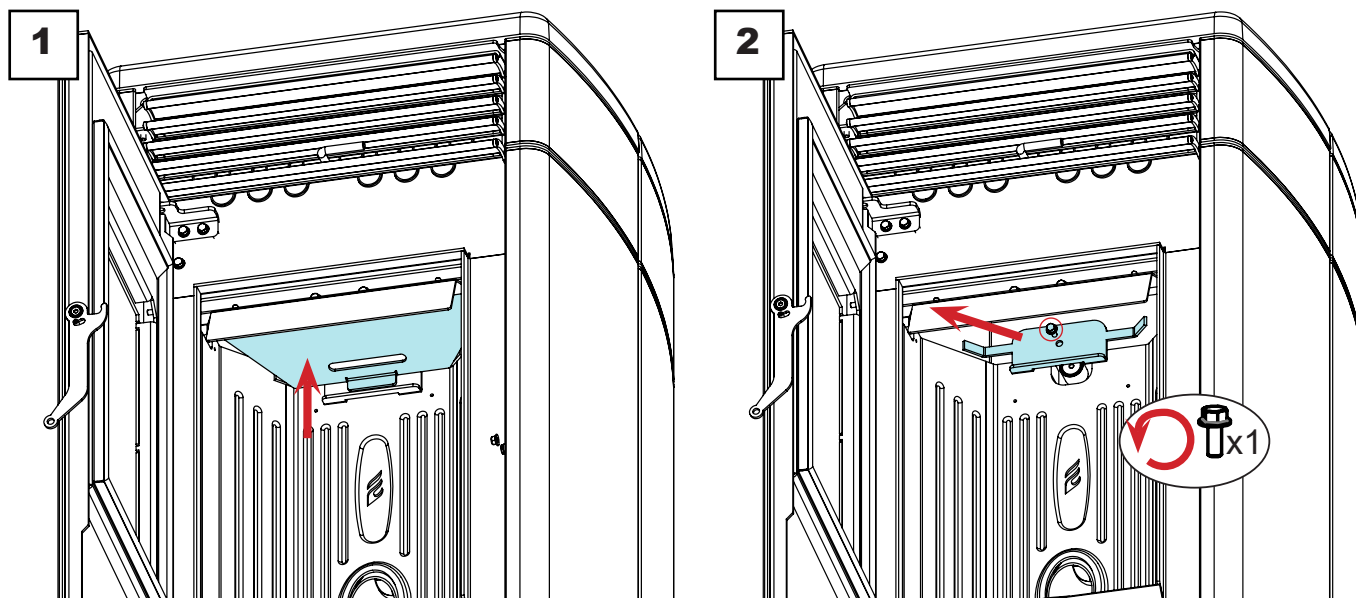

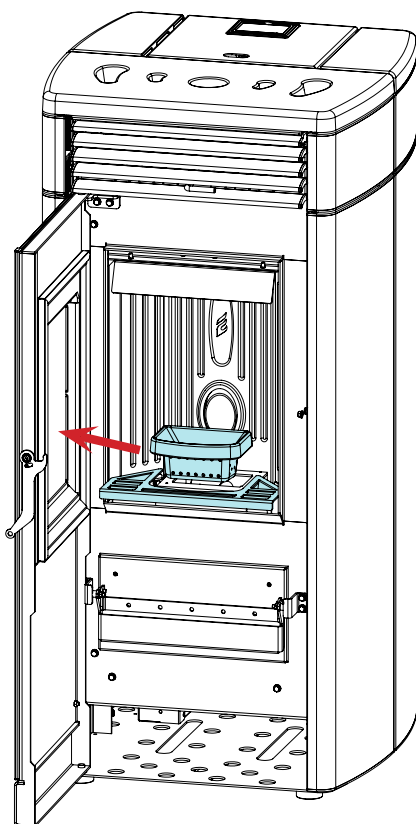
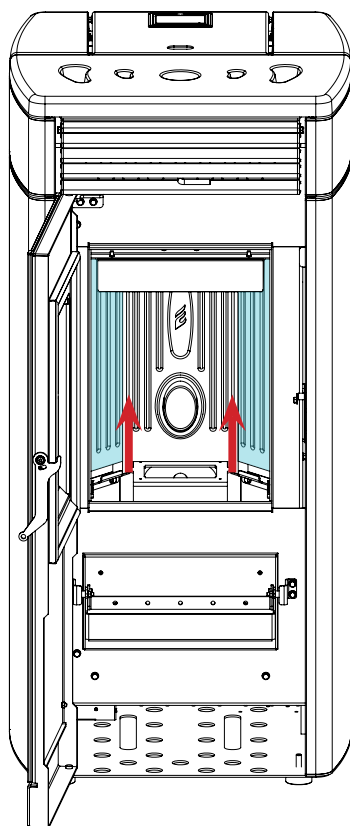
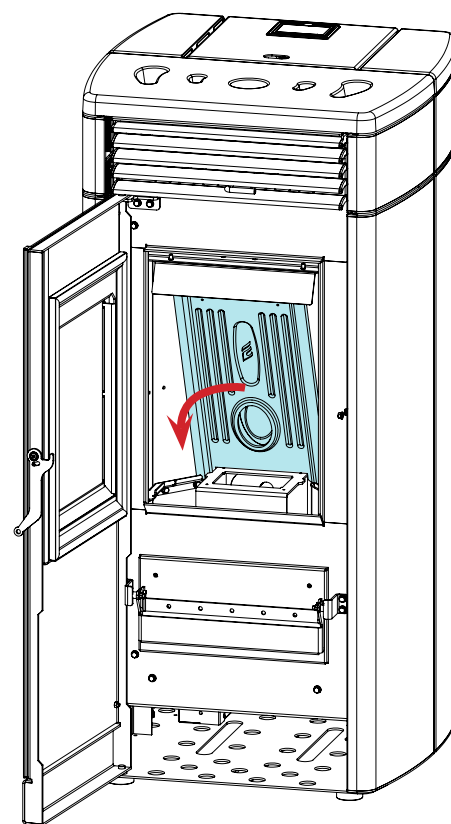
3

4

5

Checking the seals



This operation must be carried out by a Ravelli Service Centre. Plan this type of cleaning with the Ravelli Service Centre.

When thoroughly cleaning the stove, the authorised technician must check that the gaskets of

- port
- ash drawer
- hatches

are intact. If not, they will have to be replaced.

Smoke conduit cleaning



This operation must be carried out by a Ravelli Assistance Centre. Schedule this type of cleaning with the Ravelli Assistance Centre.

The stove is equipped with some hatches for cleaning the internal smoke ducts.

To clean the smoke ducts, proceed as described below:

step	action
1	Open the hatches.
2	Clean the ashes, eventually use a brush or similar and reassemble everything. Note: the hatches are equipped with gaskets, therefore, before reassembling them, make sure that the gaskets are not worn.

Note: The operation must be carried out when the stove is cold, using an ash vacuum cleaner.

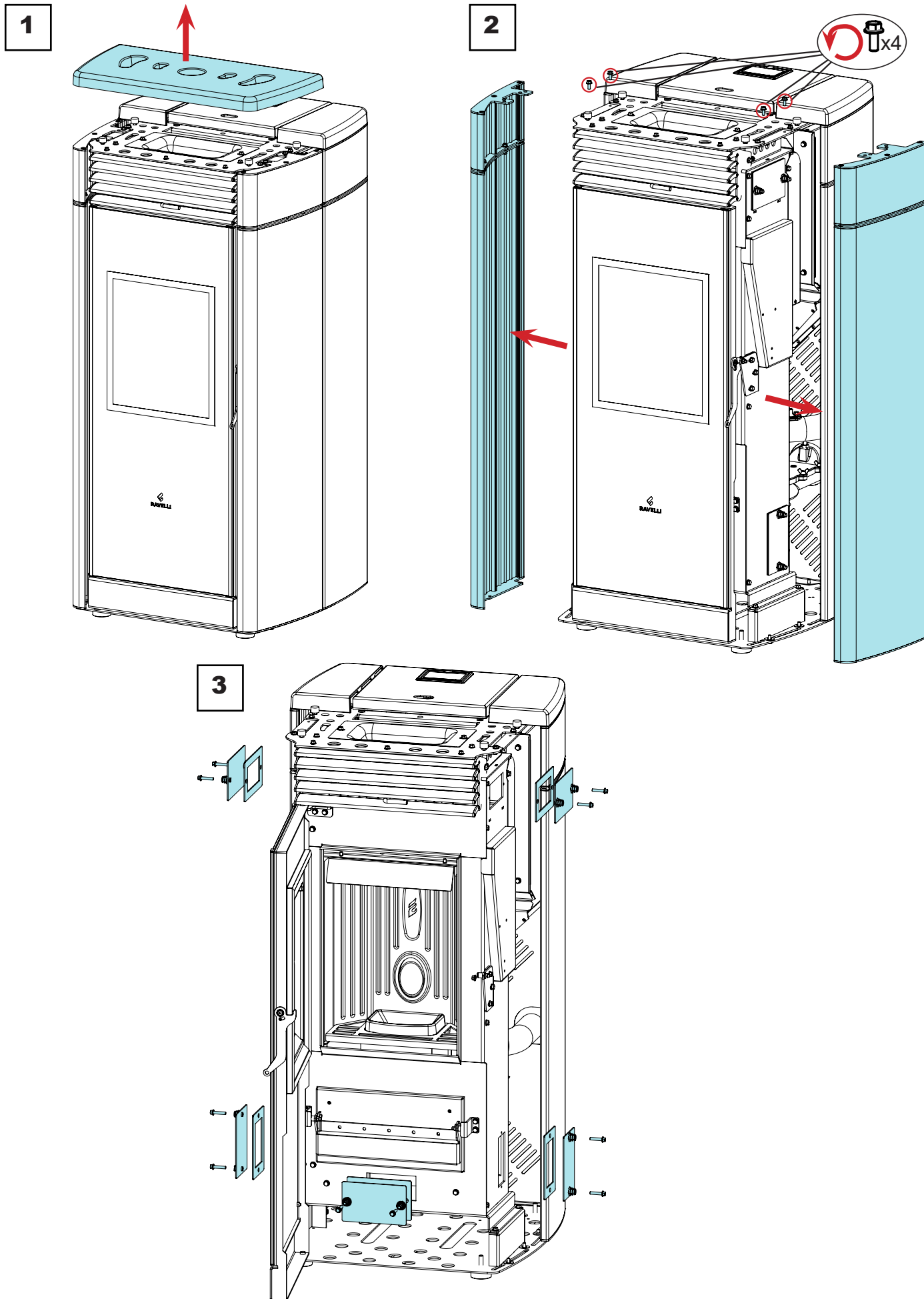

STORAGE AND DISPOSAL

Disposal

Demolition and disposal of the stove is under the exclusive liability and responsibility of the owner who must do so in accordance with the laws in force in the country of installation pertaining to safety, respect and protection of the environment.

At the end of its service life, the product must not be disposed of as household waste. It can be taken to designated separate waste collection centres run by local administrations or to dealers who offer this service.

Disposing of the product as sorted waste avoids any negative consequences on the environment and health deriving from unsuitable disposal and it recovers the materials that the stove is composed of in order to save considerable energy and resources.

TROUBLESHOOTING

The stove does not work

- closely follow the directions in the dedicated chapter of this manual.
- make sure that the air intake duct is not obstructed;
- make sure that the smoke evacuation system is clean and not obstructed;
- make sure the chimney is sized for the stove power;
- make sure that the air intake in the room is clear of any obstructions and that there are no other combustion appliances or extraction hoods that create a vacuum in the room;

Difficult lighting

- closely follow the directions in the dedicated chapter of this manual;
- make sure that the air intake duct is not obstructed;
- make sure that the smoke evacuation system is clean and not obstructed;
- make sure the chimney is sized for the stove power.
- make sure that the air intake in the room is clear of any obstructions and that there are no other combustion appliances or extraction hoods creating a vacuum in the room.

Smoke leakage

- Check the draught of the chimney.
- Check whether the seals on the door, drawer and smoke evacuation system are intact.
- Make sure there is no ash obstructing the primary air flow grille.

The glass gets dirty easily

- Only use recommended fuels.
- Check the draught of the chimney.

Downtime (end of season)

At the end of every season we recommend vacuuming out any ash and dust that may still be inside. It is advisable to let the pellets burn out in the tank so that the pellet remains and sawdust can be vacuumed from the bottom and from the screw.

Disconnect the stove from the power supply.

With thermo-stove or boiler, it is not necessary to empty it of water, but it is advisable to close the shut-off valves at the inlet and outlet for prolonged downtime.

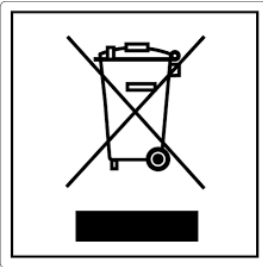

ITA-Informationi per la gestione di rifiuti di apparecchiature elettriche ed elettroniche contenenti pile e accumulatori

Questo simbolo che appare sul prodotto, sulle pile, sugli accumulatori oppure sulla loro confezione o sulla loro documentazione, indica che il prodotto e le pile o gli accumulatori inclusi al termine del ciclo di vita utile non devono essere raccolti, recuperati o smaltiti assieme ai rifiuti domestici.

Una gestione impropria dei rifiuti di apparecchiature elettriche ed elettroniche, di pile o accumulatori può causare il rilascio di sostanze pericolose contenute nei prodotti. Allo scopo di evitare eventuali danni all'ambiente o alla salute, si invita l'utilizzatore a separare questa apparecchiatura, e/o le pile o accumulatori inclusi, da altri tipi di rifiuti e di consegnarla al centro comunale di raccolta. È possibile richiedere al distributore il ritiro del rifiuto di apparecchiatura elettrica ed elettronica alle condizioni e secondo le modalità previste dal D.Lgs. 49/2014.

La raccolta separata e il corretto trattamento delle apparecchiature elettriche ed elettroniche, delle pile e degli accumulatori favoriscono la conservazione delle risorse naturali, il rispetto dell'ambiente e assicurano la tutela

della salute.

Per ulteriori informazioni sui centri di raccolta dei rifiuti di apparecchiature elettriche ed elettroniche, di pile e accumulatori è necessario rivolgersi alle Autorità pubbliche competenti al rilascio delle autorizzazioni.

ENG-Information for management of electric and electronic appliance waste containing batteries or accumulators

This symbol, which is used on the product, batteries, accumulators or on the packaging or documents, means that at the end of its useful life, this product, the batteries and the accumulators included must not be collected, recycled or disposed of together with domestic waste.

Improper management of electric or electronic waste or batteries or accumulators can lead to the leakage of hazardous substances contained in the product. For the purpose of preventing damage to health or the environment, users are kindly asked to separate this equipment and/or batteries or accumulators included from other types of waste and to arrange for disposal by the municipal waste service. It is possible to ask your local dealer to collect the waste electric or electronic appliance under the conditions and following the methods provided by national laws transposing the Directive 2012/19/EU.

Separate waste collection and recycling of unused electric and electronic equipment, batteries and accumulators helps to save natural resources and to guarantee that this waste is processed in a manner that is safe for health and the environment.

For more information about how to collect electric and electronic equipment and appliances, batteries and accumulators, please contact your local Council or Public Authority competent to issue the relevant permits.

FRA-Informations relatives à la gestion des déchets d'appareils électriques et électroniques contenant des piles et des accumulateurs

Ce symbole présent sur le produit, sur les piles, sur les accumulateurs, sur l'emballage ou sur la documentation de référence, indique que le produit et les piles ou les accumulateurs ne doivent pas être collectés, récupérés ou éliminés avec les déchets domestiques au terme de leur vie utile.

Une gestion improprie des déchets d'équipements électriques et électroniques, des piles ou des accumulateurs peut causer la libération de substances dangereuses contenues dans les produits. Pour éviter d'éventuelles atteintes à l'environnement ou à la santé, on invite l'utilisateur à séparer cet appareil, et / ou les piles ou les accumulateurs, des autres types de déchets et de le confier au service municipal de collecte. On peut demander au distributeur de prélever le déchet d'appareil électrique ou électronique aux conditions et suivant les modalités prévues par les normes nationales de transposition de la Directive 2012/19/UE.

La collecte sélective et le traitement correct des appareils électriques et électroniques, des piles et des accumulateurs, favorisent la conservation des ressources naturelles, le respect de l'environnement et assurent la protection de la santé.

Pour tout renseignement complémentaire sur les modalités de collecte des déchets d'appareils électriques et électroniques, des piles et des accumulateurs, il faut s'adresser aux Communes ou aux Autorités publiques compétentes pour la délivrance des autorisations.

NLD-Informatie voor het beheer van afgedankte elektrische en elektronische apparatuur die batterijen en accu's bevat

Dit symbool, dat op het product, op batterijen, op accu's, op de verpakking of in de documentatie ervan staat, geeft aan dat het product en de batterijen of accu's aan het einde van de gebruiksduur niet samen met het huishoudelijke afval mogen worden ingezameld of verwijderd.

Een onjuist beheer van afgedankte elektrische en elektronische apparatuur, batterijen of accu's kan leiden tot het vrijkomen van gevaarlijke stoffen in de producten. Om schade aan het milieu of aan de gezondheid te voorkomen, wordt de gebruiker aangemoedigd om deze apparatuur en/of de meegeleverde batterijen of accu's van andere soorten afval te scheiden en af te leveren aan de gemeentelijke ophaaldienst. Het is mogelijk om de distributeur te vragen om de afvalinzameling van elektrische en elektronische apparatuur uit te voeren volgens de voorwaarden en de voorschriften die zijn vastgelegd in de nationale bepalingen ter uitvoering van Richtlijn 2012/19/EU.

De gescheiden inzameling en correcte behandeling van elektrische en elektronische apparatuur, batterijen en accu's bevorderen het behoud van natuurlijke hulpbronnen, respect voor het milieu en zorgen voor de bescherming van de gezondheid.

Voor meer informatie over de inzameling van afgedankte elektrische en elektronische apparatuur, batterijen en accu's is het noodzakelijk om contact op te nemen met de gemeenten of de bevoegde overheidsinstanties.

DEU-Informationen für die Entsorgung von elektrischen und elektronischen Altgeräten, die Batterien und Akkus enthalten

Dieses Symbol auf dem Produkt, auf den Batterien, auf den Akkus, auf deren Verpackung oder in deren Unterlagen weist darauf hin, dass das Produkt und die Batterien oder Akkus am Ende ihrer Lebensdauer nicht zusammen mit dem normalen Hausmüll gesammelt, verwertet oder entsorgt werden dürfen.

Eine unsachgemäße Entsorgung von elektrischen und elektronischen Altgeräten, sowie von Batterien oder Akkus kann zur Freisetzung gefährlicher Stoffe im Produkt führen. Um mögliche Umwelt- oder Gesundheitsschäden zu vermeiden, wird der Benutzer aufgefordert, dieses Gerät bzw. die Batterien oder Akkus von anderen Abfallarten zu trennen und der kommunalen Sammelstelle zu übergeben. Außerdem ist es möglich, den Händler um die Rücknahme der elektrischen und elektronischen Altgeräte unter den in den nationalen Vorschriften zur Umsetzung der Richtlinie 2012/19/EU vorgesehenen Bedingungen zu bitten.

Die getrennte Sammlung und die ordnungsgemäße Verwertung von elektrischen und elektronischen Altgeräten, Batterien und Akkus fördert die Erhaltung der natürlichen Ressourcen, respektiert die Umwelt und gewährleistet den Schutz der Gesundheit.

Für weitere Informationen zur Sammlung von elektrischen und elektronischen Altgeräten, Batterien und Akkus wenden Sie sich bitte an die für die Erteilung von Genehmigungen zuständigen Kommunen oder Behörden.

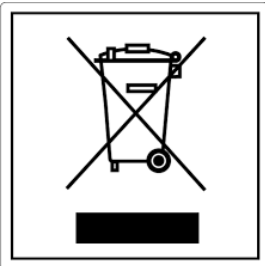

ESP-Información para la gestión de residuos de aparatos eléctricos y electrónicos con pilas y acumuladores

Este símbolo que aparece en el producto, en las pilas, los acumuladores o en su embalaje o su documentación indica que el producto y las pilas o acumuladores que contiene, al final de su vida útil, no deben recogerse, recuperarse o desecharse junto con los residuos domésticos.

Una gestión inadecuada de los residuos de aparatos eléctricos y electrónicos, pilas o acumuladores podría provocar la liberación de sustancias peligrosas contenidas en los productos. Para evitar posibles daños para el medio ambiente o la salud, se recomienda al usuario que separe este aparato y/o las pilas o acumuladores que contiene de otros tipos de residuos y lo entregue al servicio municipal encargado de la recogida. Se puede solicitar al distribuidor la recogida de los residuos de aparatos eléctricos y electrónicos en las condiciones y de acuerdo con las modalidades establecidas por las normas nacionales de transposición de la Directiva 2012/19/UE.

La recogida diferenciada y el tratamiento correcto de los aparatos eléctricos y electrónicos, de las pilas y los acumuladores favorecen la conservación de los recursos naturales, el respeto del medio ambiente y garantizan la protección de la salud.

Para obtener más información sobre las modalidades de recogida de los residuos de aparatos eléctricos y electrónicos, de las pilas y los acumuladores es necesario acudir a los ayuntamientos o las autoridades públicas competentes para la concesión de autorizaciones.

PRT-Informações sobre a gestão dos resíduos de equipamentos elétricos e eletrônicos contendo pilhas e acumuladores

Este símbolo no produto, pilhas, acumuladores ou respetiva embalagem ou documentação indica que, no final do seu ciclo de vida útil, o produto e os acumuladores incluídos não devem ser recolhidos, recuperados nem eliminados conjuntamente com o lixo doméstico.

Uma gestão imprópria dos resíduos de equipamentos elétricos e eletrônicos, pilhas ou acumuladores pode causar a libertação de substâncias perigosas contidas nos produtos. A fim de evitar eventuais danos para o ambiente ou para a saúde, o utilizador é convidado a separar este equipamento e/ou pilhas ou acumuladores incluídos de outros tipos de resíduos e a depositá-los no serviço municipal de recolha de lixo. É possível requisitar a recolha dos resíduos de equipamentos elétricos e eletrônicos pelo distribuidor segundo as condições e modalidades previstas pelas normas nacionais de transposição da diretiva 2012/19/UE.

A recolha separada e o correto tratamento dos equipamentos elétricos e eletrônicos e respetivas pilhas e acumuladores favorecem a conservação dos recursos naturais, o respeito do ambiente e a proteção da saúde.

Para mais informações sobre as modalidades de recolha dos resíduos de equipamentos elétricos e eletrônicos, pilhas e acumuladores, dirija-se à sua Câmara Municipal ou à autoridade pública competente para a emissão das autorizações.

GRC-Πληροφορίες για τη διαχείριση αποβλήτων ηλεκτρικού και ηλεκτρονικού εξοπλισμού, μπαταριών και συσσωρευτών

Αυτό το σύμβολο που εμφανίζεται στο προϊόν, στις μπαταρίες, στους συσσωρευτές στη συσκευασία ή στα έγγραφα υποδεικνύει ότι το προϊόν στο τέλος της ωφέλιμης ζωής του δεν πρέπει να συλλέγεται, να ανασύρεται ή να απορρίπτεται με τα οικιακά απορρίμματα.

Ο ακατάλληλος χειρισμός των αποβλήτων ηλεκτρικού και ηλεκτρονικού εξοπλισμού, μπαταριών ή συσσωρευτών μπορεί να οδηγήσει στην απελευθέρωση επικίνδυνων ουσιών που περιέχονται στο προϊόν. Προκειμένου να αποφευχθεί τυχόν μόλυνση στο περιβάλλον ή ασθένεια, ο χρήστης ενθαρρύνεται να διαχωρίσει αυτόν τον εξοπλισμό ή/και τις μπαταρίες ή τους συσσωρευτές που περιλαμβάνονται από άλλα είδη αποβλήτων και να το παραδώσει στην υπηρεσία δημοτικών συλλογών. Είναι δυνατόν να ζητηθεί από τον διανομέα η συλλογή αποβλήτων ηλεκτρικού και ηλεκτρονικού εξοπλισμού που πρέπει να πραγματοποιηθεί σύμφωνα με τους όρους και με τις διαδικασίες που θεσπίζονται από τις εθνικές διατάξεις εφαρμογής της οδηγίας 2012/19/ΕΕ.

Η χωριστή συλλογή και η σωστή επεξεργασία ηλεκτρικού και ηλεκτρονικού εξοπλισμού, μπαταριών και συσσωρευτών ευνοούν τη διατήρηση των φυσικών πόρων, τον σεβασμό για το περιβάλλον και την προστασία της υγείας.

Για περισσότερες πληροφορίες σχετικά με τον τρόπο συλλογής των αποβλήτων ηλεκτρικού και ηλεκτρονικού εξοπλισμού, μπαταριών και συσσωρευτών είναι απαραίτητο να επικοινωνήσετε με τους δήμους ή τις δημόσιες αρχές που είναι αρμόδιες για την έκδοση των αδειών.

DNK-Informationer til behandling af affald fra elektriske og elektroniske udstyr der indeholder batterier og akkumulatorer

Dette symbol, der vises på produktet, på batterierne eller på akkumulatorerne, på indpakningen eller i dokumentationen, angiver at selve produkt, når dets levetid er opbrugt, ikke skal opsamles, genvindes eller bortskaffes sammen med normalt husholdningsaffald.

En ukorrekt behandling af affald fra elektriske eller elektroniske udstyr, af batterier og akkumulatorer, risikerer at udløse farlige stoffer indeholdt i produktet. For at forebygge ventuelle skader for miljøet eller sundheden, bedes brugeren om at behandle dette udstyr, og/eller de medfølgende batterier eller akkumulatorerne separat fra andre affaldstyper, og at levere det til det kommunale opsamlingscenter, eller at anmode leverandøren om opsamling, i henhold til forskrifterne, der er angivet i de nationale forordninger til gennemførelse af Direktivet 2012/19/EF.

Den separate opsamling og genvinding af de nedslidte elektriske og elektroniske udstyr, af batterierne og af akkumulatorerne, fremmer bevarelsen af de naturlige ressourcer, og sikrer at dette affald behandles ved at tage hensyn til miljøets og sundhedens varetagelse.

Til yderligere informationer angående opsamling af affald fra elektriske og elektroniske udstyr, af batterier og akkumulatorer, er det nødvendigt at rette henvendelse til Kommunerne eller til de ansvarlige myndigheder til udstedelse af bemyndigelserne.

POL-Informacje dotyczące zarządzania odpadami sprzętu elektrycznego i elektronicznego zawierającego baterie i akumulatory

Niniejszy symbol znajdujący się na produkcie, bateriach, akumulatorach, na ich opakowaniu lub na dokumentacji, wskazuje, że produkt, baterie lub akumulatory po zakończeniu okresu użytkowania nie mogą być zbierane, odzyskiwane lub utylizowane wraz z odpadami komunalnymi.

Niewłaściwe postępowanie ze użytym sprzętem elektrycznym i elektronicznym, bateriami lub akumulatorami może powodować uwolnienie niebezpiecznych substancji zawartych w produktach. Celem uniknięcia jakichkolwiek szkód dla środowiska lub zdrowia, użytkownik proszony jest o odseparowanie niniejszego sprzętu i/lub dołączonych baterii lub akumulatorów od innych rodzajów odpadów i dostarczenia go do miejskiego punktu zbierania odpadów. Możliwe jest zwrócenie się z prośbą do dystrybutora o odebranie odpadów sprzętu elektrycznego i elektronicznego, na warunkach i zgodnie z procedurami ustanowionymi przez przepisy krajowe transponujące dyrektywę 2012/19/UE.

Oddzielna zbiórka i prawidłowe przetwarzanie sprzętu elektrycznego i elektronicznego, baterii i akumulatorów sprzyja ochronie zasobów naturalnych, poszanowaniu środowiska i zapewnieniu ochrony zdrowia.

Aby uzyskać więcej informacji dotyczących zbiórki użytego sprzętu elektrycznego i elektronicznego, baterii i akumulatorów, należy skontaktować się z władzami miejskimi lub organami publicznymi odpowiedzialnymi za wydawanie zezwoleń.

SVN-Informacije o ravnanju z odpadno električno in elektronsko opremo, ki vsebuje baterije in akumulatorje

Ta simbol, ki se nahaja na izdelku, baterijah, akumulatorjih ali na njihovi embalaži ali v dokumentaciji, označuje, da se po izteku življenjske dobe izdelka ter baterij ali akumulatorjev, ki jih izdelek vsebuje, ne sme zbirati, predelati ali odstranjevati skupaj z odpadki iz gospodinjstev.

Neprimerno ravnanje z odpadno električno in elektronsko opremo, baterijami ali akumulatorji lahko povzroči izpust nevarnih snovi, ki jih vsebujejo izdelki. Da bi preprečili morebitne škodljive vplive na okolje ali zdravje, uporabnike pozivamo, da tovrstno opremo in/ali baterije ali akumulatorje, ki jih oprema vsebuje, ločujejo od drugih vrst odpadkov ter jih oddajo občinski službi za zbiranje odpadkov. Od distributerja lahko zahtevate prevzem odpadne električne in elektronske opreme pod pogoji in na načine, skladno s katerimi je bila Direktiva 2012/19/EU prenesena v nacionalno zakonodajo.

Ločevanje in ustrezna obdelava električnih in elektronskih naprav, baterij in akumulatorjev pripomoreta k ohranjanju naravnih virov, spoštovanju okolja ter zagotavljanju varovanja zdravja.

Za dodatne informacije o načinih zbiranja odpadne električne in elektronske opreme, baterij in akumulatorjev se obrnite na občine ali na javne organe, ki so pristojni za izdajanje dovoljenj.



Aico S.p.A.

Headquarter

Via Consorzio Agrario, 3/D - 25032
Chiari (BS) - Italy

Research and Development Centre

Viale del commercio 12/a - 37135
Verona (VR) - Italy

T. + 39 030 7402939
info@ravelligroup.it

FB Ravellifuocointelligente
IG ravellistufe

www.ravelligroup.it

Aico S.p.A. does not assume any responsibility for any errors in this booklet and considers itself free to make any variations to the features of its products without notice.